

# Modelling the Dynamics of Cognitive Depressogenic Thought Formation

Azizi A. Aziz (mraaziz@few.vu.nl)

Agent Systems Research Group, Department of Artificial Intelligence  
Faculty of Science, Vrije Universiteit Amsterdam,  
De Boelelaan 1081a, 1081 HV Amsterdam, The Netherlands

## Abstract

Cognitive vulnerabilities provide a clear link of how individuals are exposed to the elements of the risk in hopelessness, and later the formation of recurrence and relapse in depression. It has also been associated with the negative social support and inferential styles. Therefore, it is crucial to understand how these concepts are interrelated, and defined. This paper present a model of the dynamics of a human's developmental state in relation to social support and negative cognitive thought (cognitive depressogenic thought). Theory in cognitive vulnerability is used to serve as a foundation of this model. Simulation experiments under different parameter settings pointed out that the model is able to produce related behaviour as described in several literatures. In addition, using a mathematical analysis, the equilibria of the model has been determined and analyzed.

**Keywords:** Risk of Relapse and Recurrence in Depression, Hopelessness, Cognitive Depressogenic Thought, Cognitive Vulnerability.

## Introduction

Cognitive vulnerability is one of the main concepts that play an important role to escalate the risk of relapse in affective disorder (depression). In a broader spectrum, it is a defect belief, or structures that are persistently related for later emergent in psychological problems. Therefore, by understanding this vulnerability and ways to overcome it, a risk of relapse or recurrences in depression can be reduced. Before further reviewing the underlying concepts of this vulnerability, it is essential to understand its connection with relapse condition in unipolar depression and social support. Unipolar depression is a mental disorder, distinguished by a persistent low mood and loss of awareness in usual activities (Segal, et al. 2003). Normally, under a certain degree of stressors exposure, an individual with a history of depression will develop a negative cognitive content (thought), associated with the past losses. Such cognitive content is often related to the maladaptive schemas, which in a long run will cause individual's ongoing thought capability to be distorted and later to be dysfunctional (Beck, 1987).

However, this cognitive distortion can be reduced through appropriate support from other members within the social support network (Roberts & Gotlib, 1997). Social support network is made up of friends, family and peers. Some of it might be professionals and support individuals in very specific ways, or other people in this network might be acquaintances in contact with every day (Heller & Rook,

1997). It has been suggested that social support naturally can help to prevent and decrease stress through positive inferences, which later curbs the formation of cognitive vulnerability. However, some literatures shown that certain supports provide contrast effects (Coyne, 1990; Panzarella & Alloy, 1995; DeFronzo et al., 2001). Rather than attenuating the negative effects from stressors, it eventually amplifies the individual's condition to get worse.

In this paper, these positive and negative effects from social support interaction and its relation with cognitive thought are explored. To fulfil this requirement, a dynamic model about cognitive depressogenic thought is proposed. The proposed model can be used to approximate a human's cognitive depressogenic thought progression throughout time. This paper is organized as follows. The first section introduces main concepts and existing theory of cognitive depressogenic thought and hopelessness. Thereafter, a formal model is described. The model has been simulated and later followed by a mathematical analysis. Finally, conclusion summarizes the paper with a discussion and future work for this model.

## Underlying Concepts in Cognitive Depressogenic Thought

Although it is well documented that social support mitigates a risk of relapse, there is a condition where feedbacks from the social support members may indirectly escalate the risk of relapse (DeFronzo et al., 2001). Such feedbacks are considered as "maladaptive inferential feedback" (MIF), and normally increase the negative thought formation. Prolong exposure towards this effect will later develop a serious cognitive vulnerability. Contrary to this, an adaptive inferential feedback (AIF) provides a buffer to reduce the threat, by countering negative inferences for negative event (DeFronzo et al., 2001). AIF asserts that when a social support member offers comfort by attributing the source of negative event to be unstable, or implies that event directs neither negative consequence (characteristics) towards that individual, it will later diminish the risk of creating maladaptive inferences.

These conditions also can be explained through the Expanded Hopelessness Theory of Depression. It elaborates the possibility of social processes with the presence of negative cognitive thought, and stress will later contribute to the development of vulnerability towards depression (Dobkin et al., 2004; Panzarella et al., 2006). Major focus of this theory is the specific mechanisms which inferential

feedback (both AIF and MIF) may influence the development of hopelessness, cognitive depressogenic thought, and later vulnerability in depression. However, this paper will be focusing more to the formation of cognitive depressogenic thought while retaining important aspects of theory.

According to Alloy et al. (1999), there is an evident to show that individuals response differently towards stressful life events. Some individuals may develop severe or long lasting depression, while others stay healthy or develop mild and short-lived depression. This is the result from individuals' interpretation towards their experience influences over the negative event, resulting from the formation of cognitive depressogenic thought. Cognitive depressogenic thought refers to the negative style of thinking, characterized by a tendency to attribute negative events to be persistent and widespread in many aspects of life (Abramson et al., 1999; Alloy et al., 2004). Individuals with this condition are likely to infer the negative life events as self-attributions of being worthless and flawed. As a result, these particular individuals are exposing themselves towards vulnerability of recurrence or relapse in depression.

The Expanded Hopelessness Theory of Depression relates the development cognitive depressogenic thought through two precursors. First, the present of positive social support feedback (AIF) acts as a buffer to reduce individuals' possibility of having cognitive depressogenic thought over time. Second, individuals with cognitive depressogenic thought will make negative inferences when facing negative events. This condition is also associated with less AIF from the social support members (Panzarella et al., 2006). Moreover, both of these conditions capable to predict changes in stressful events. Therefore, it can be further used to elaborate the immunity level of individuals (as contrast in vulnerability concept). In addition, many studies have also associated the lower risk of depression with the presence of AIF (Alloy et al., 2000; Crossfield et al, 2002).

As indicated in several previous works, inferential feedbacks provide one of the substantial factors towards the development of cognitive depressogenic thought over time. By combining either one of these two factors together with situational cues, it leads to the formation of either cognitive depressogenic inference or positive attributional style. Situational cues refers to a concept that explains individuals' perception that highly influenced by cues from events (environment). Individuals under the influence of negative thought about themselves will tend to reflect these negative cognitions in response to the occurrence of stressors. These later develop the conditions called "stress-reactive rumination" and "maladaptive inference". Stress reactive rumination reflects a condition where individuals have difficulty in accessing positive information, and further develop a negative bias towards inference (maladaptive inference) (Spasojevic & Alloy, 2001; Robinson & Alloy, 2003). This process is amplified by previous exposures towards cognitive depressogenic thought episode. After a

certain period, both conditions are related to the formation of hopelessness. Hopelessness is defined by the expectation that desired outcome will not occur, or there is nothing one can do to make it right (Abramson et al., 1989). Prolong and previous exposure from hopelessness will lead to the development of cognitive depressogenic thought. However, this condition can be reduced by having a positive attributional style, normally existed during the presence of AIF and low situational cues perception (Dobkin et al., 2004).

In short, the following relations can be identified from the literature: (1) prolong exposure towards MIF, negative events, and high-situational cues can lead to the development of cognitive depressogenic thought. (2) a proper support (AIF) will reduce the risk of further development of future cognitive depressogenic thought. (3) Individuals with high situational cues and proper support will be less effective in reducing the progression of cognitive depressogenic thought, compared to the individuals with less situational cues.

### Modelling Approach

This section discusses the details of the dynamic model. The characteristics of the proposed model are heavily motivated by the research discussed in the previous section. In this model, three major components will represent the dynamic of interactions between social support feedback and individuals involved in negative thought formation during the brink of relapse and recurrence in depression. These components are; environment, inferential feedbacks, and thought formation. Environment explains the condition of stressors, while inferential feedbacks represent the inferential style communicated by the social support members to the individuals and, finally thought formation summarizes the interaction results from those conditions. By coupling these main concepts, it provides a building block in designing an individual model for cognitive depressogenic thought. Figure 1 depicts the relationship between the details of these components.

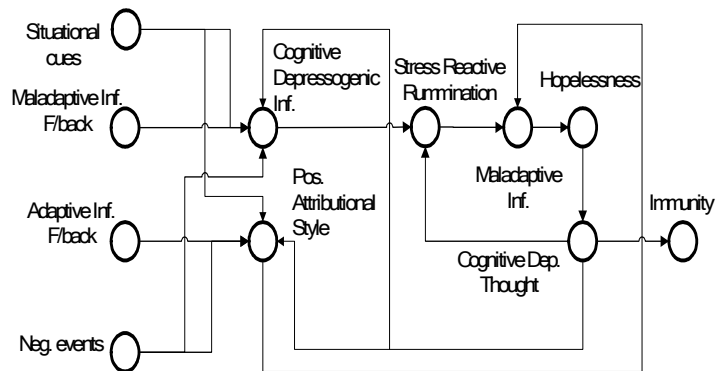

Figure 1: Model of Cognitive Depressogenic Thought Dynamics

Once the structural relationships in the model have been determined, then model later can be formalized. During the formalization process, all nodes are designed in a way to hold values ranging from 0 (low) to 1 (high). Interaction among interrelated nodes will determine the new value of it, either by a series of accumulative or instantaneous effects. The following explains the detail of the model.

**Negative events (NEVt):** In the model, the negative events are generated by simulating several dynamic  $t$  time conditions using weighted sum  $w$ , of major events; life events ( $Le$ ), chronic ( $Ce$ ), and daily ( $De$ ) events.

$$NEVt(t) = w_1.Le(t) + w_2.Ce(t) + W_3.De(t), \quad \sum_{n=1}^i w_n = 1, i=3$$

In this case, the role of these events is to represent the condition of stressors. These events are seen as very intense (high negative event) when  $NEVt(t) \rightarrow 1$ , and less-intense when  $NEVt(t) \rightarrow 0$ .

**Situational cues (SiC):** Situational cues are computed by combining three factors together; consistency ( $CtC$ ), consensus ( $CsC$ ), and distinctiveness ( $DtC$ ) cues. Higher situational cues represent a condition where an individual will behave according to the external environment rather than individual's intellect or dispositional.

$$SiC(t) = \varpi_1.CtC(t) + \varpi_2.CsC(t) + \varpi_3.DtC(t), \quad \sum_{n=1}^i \varpi_n = 1, i=3$$

**Cognitive depressogenic inferences (CDi)** explains the combination of maladaptive inferential style ( $MiF$ ) with several components, namely; situational cues ( $SiC$ ), cognitive depressogenic thought ( $CdT$ ), and negative events ( $NEVt$ ). The  $\alpha$  value is used to distribute the proportion of contributions among these variables in this equation.

$$CDi(t) = \alpha.MiF(t) + (1-\alpha). [SiC(t).CdT(t).NEVt(t)]. MiF(t)$$

**Positive attributional style (PtS)** is an attributional style that is highly related to an adaptive inferential style ( $AiF$ ). It also has a negative relationship with bad situational cues, negative events, and cognitive depressogenic thought.

$$PtS(t) = \eta.AiF(t) + (1-\eta). [1-(SiC(t). NEVt(t). CdT(t))]. AiF(t).$$

**Stress reactive rumination (SrR)** is based on the interaction between cognitive depressogenic inference and cognitive depressogenic thought. The  $\beta$  is used to regulate the contribution of these variables.

$$SrR(t) = \beta.CDi(t) + (1-\beta). CdT(t)$$

**Maladaptive inference (Mdi)** has a positive relationship with stress reactive rumination, and contrary for the positive attributional style. This opposite effect reflects the condition of stress buffering concept delivered by positive social

support feedbacks. The intensity of this inference process is controlled by  $\gamma$ .

$$Mdi(t) = \gamma.SrR(t).(1-PtS(t))$$

**Hopelessness (Hps) and Cognitive depressogenic thought (CdT)** are derived from the accumulative (temporal relation) process of certain cases in a time interval between  $t$  and  $\Delta t$ . Hopelessness relates with the formation of maladaptive inference, while the hopelessness is related to the development of cognitive depressogenic thought. These relationships are formulated as the following;

$$Hps(t+\Delta t) = Hps(t) + (1-Hps(t)). \psi.(Mdi(t) - \phi.Hps(t)). Hps(t).\Delta t$$

$$CdT(t+\Delta t) = CdT(t) + (1-CdT(t)). \varphi.(Hps(t) - \tau.CdT(t)). CdT(t).\Delta t$$

where  $\psi$ ,  $\varphi$ ,  $\phi$ , and  $\tau$  denote the proportion of changes for all respective equations.

**Immunity (Im)** has a negative relationship with the formation of cognitive depressogenic thought. The value of  $\gamma$  provides the proportional rate of the contribution between based-immunity ( $Imnorm$ ) and cognitive depressogenic thought.  $Imnorm$  represents the baseline immunity for each individual.

$$Im(t) = \gamma.Imnorm + (1-\gamma).(1-CdT(t)). Imnorm$$

Using all defined equations, a simulator has been developed for experimentation purposes, specifically to explore interesting patterns on inferential feedbacks and depressogenic thought. Figure 2 depicts the screenshot of the simulator.

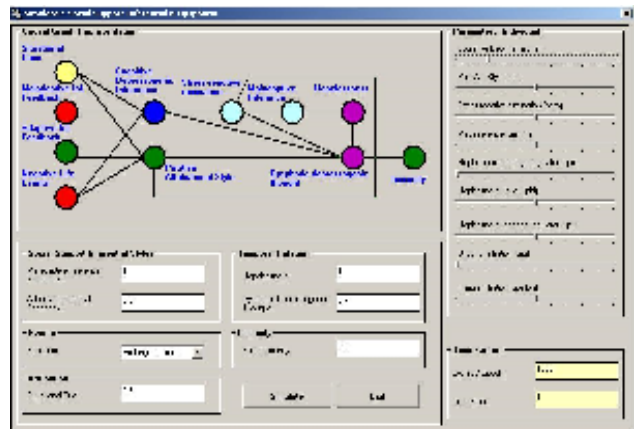

Figure 2: A Screenshot for the Developed Prototype

This simulator is designed and developed under a visual programming platform. It allows a graphical user interface for experimental and parameters settings purposes.

## Simulation Traces

In this section, the model was executed to simulate several conditions of individuals with the respect of exposure towards negative events, feedbacks from the social support members, and situational cues. With variation of these conditions, some interesting patterns can be obtained, as previously defined in the earlier section. For simplicity, this paper shows several cases of cognitive depressogenic thought levels formation using three different individual attributes. These cases are; (i) an individual *A* with a good feedbacks from the social support members, and using a good judgment about the situation, (ii) an individual *B* that receives good feedbacks but with bad judgment about the situation, and (iii) an individual *C* with bad feedbacks from the social support, and bad judgment about the situation.

Table 1: Individual Profiles

Individual	Parameters Setting
A	$SiC=0.2, MiF=0.1, AiF=0.8$
B	$SiC=0.8, MiF=0.1, AiF=0.9$
C	$SiC=0.9, MiF=0.8, AiF=0.1$

The duration of the simulated scenario is up to  $t = 1000$  (to represent the conditions within 42 days) with three negative events. The first event consisted of the prolonged and gradually decreased stressors, while the second event dealt with the decreased stressor. The third event simulates the repeated stressors. For all conditions, the initial cognitive depressogenic thought was initialized as 0.5.

### Case # 1: Prolonged Repeated Stressor with Different Individuals Inferential Feedback and Situation Cues

During this simulation, each type of individual attribute has been exposed to a prolonged stressor condition. The result of this simulation is shown in Figure 3.

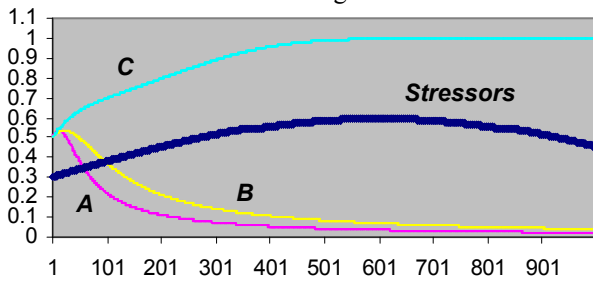

Figure 3 Cognitive Depressogenic Level for Each Individual during Prolonged Stress

In this simulation trace, it shown that an individual *C* (*high situational cues*, and *negative inferential feedback*) tends to develop a cognitive depressogenic thought, in contrast with the others. Individual *A* (*low situational cues*, and *positive inferential feedback*) shows a rapid declining pattern in developing the cognitive condition. Note that the individual *B* (*high situational cues* and *positive inferential feedback*) has also developed a decreasing pattern towards the cognitive condition. However, the individual *B* has a lesser

decreasing effect towards negative thought despite a high positive support, since this individual tends to perceive negative view about the situation. Persistent positive support from the social support members helps him/her to reduce the development of cognitive thought throughout time.

### Case #2: Decreased Stressor with Different Individual Inferential Feedback and Situational Cues

In this simulation trace, there are two conditions were introduced, one with a very high constant stressor, and with no stressor event. These events simulate the condition of where individuals were facing a sudden change in their life, and how inferential feedbacks and perceptions towards events play important to role towards the diminishing of cognitive thought. The result of this simulation is shown in Figure 4.

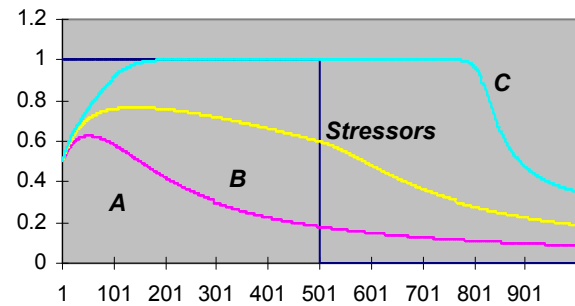

Figure 4: Dysphoric Depressogenic Level for Each Individual during Fluctuated Stressors

A comparison for each individual shows that individual *C* gets into a sharp progression towards a high cognitive thought after direct exposure towards a heightened stressor. At the start of high constant stressor, both individuals *A* and *B* develop cognitive thought. However, after certain time points, those progression dropped and reduced throughout time. As for the individual *C*, even the stressors have been diminished, the level cognitive depressogenic thought was still high for several time points until it decreased.

### Case # 3: Rapid Repeated Stressors with Different Individual Inferential Feedback and Situational Cues

For this simulation, each type of individual has been exposed to a stream of repeated stressors, with a rapid alteration between each event. In a real situation, it simulates the cumulative effect conditions, where repeated strikes had the effect of escalating the overall intensity of stressors.

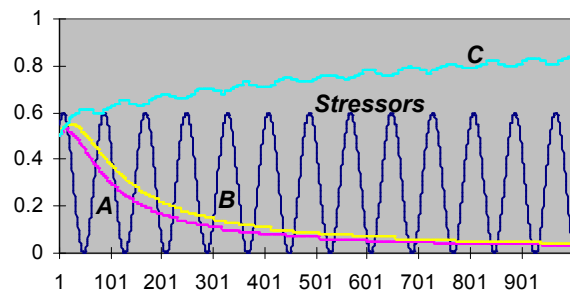

Figure 5: Cognitive Depressogenic Level for Each Individual during Repeated Stressors

Figure 5 illustrates the effects of repeated stressors condition towards different individuals. Note that the individual *C* develops a gradual increasing level of cognitive thought, while both individuals *A* and *B* show a contrast effect. Using a similar experimental setting, by using  $t_{max}=5000$ , the end of the experimental results show individual *C* will have a persistent cognitive depressogenic value equal to 1.

## Mathematical Analysis

In this section, the equilibria properties are analyzed using a mathematical formal analysis. The equilibria explains condition where the values for the variables which no change occur. This condition can be represented as having any differences in temporal function between time point  $t$  and  $t+\Delta t$  are equal to zero (in particular for both temporal relations in *Hps* and *CdT*). To obtain possible equilibria values for the other variables, first the model is described in a differential equation form. In addition, to achieve these equilibria, all external conditions are assumed constant.

- i)  $dCdT(t)/dt = (1-CdT) \cdot \varphi \cdot (Hps - \tau \cdot CdT) \cdot CdT$
- ii)  $dHps(t)/dt = (1-Hps) \cdot \psi \cdot (Mdl - \phi \cdot Hps) \cdot Hps$

Next, the equations are identified describing

- i)  $dCdT(t)/dt = 0$
- ii)  $dHps(t)/dt = 0$

Therefore, these are equivalent to;

- i)  $CdT=1$  or  $Hps = \tau \cdot CdT$  or  $CdT=0$
- ii)  $Hps=1$  or  $Mdl = \phi \cdot Hps$  or  $Hps=0$

From here, a first of conclusions can be derived where the equilibrium can only occur when the cognitive depressogenic thought level is equal to 1, hopelessness equals the cognitive depressogenic thought (if  $\tau=1$ ), or no cognitive depressogenic thought takes place. By combining these three conditions, it can be re-written into a set of relationship in  $(A \vee B \vee C) \wedge (D \vee E \vee F)$  expression:

$$(Hps = 1 \vee Mdl = \phi \cdot Hps \vee Hps = 0) \wedge (CdT = 1 \vee Hps = \tau \cdot CdT \vee CdT = 0)$$

From this, this expression can be elaborated using the *law of distributivity* as  $(A \wedge D) \vee (A \wedge E) \vee \dots \vee (C \wedge F)$ . This later provides possible combinations equilibria points to be further analyzed.

### Condition # 1: $CdT=1$

From this case, it can be further derived that respective values for the equilibrium condition to take place. These values can be calculated from the following formulae.

$$\begin{aligned} CDi &= \alpha \cdot MiF + (1-\alpha) \cdot (SiC \cdot NEvt \cdot MiF) \\ PtS &= \eta \cdot AiF + (1-\eta) \cdot (1-(SiC \cdot NEvt)) \cdot AiF \\ SrR &= \beta \cdot [\alpha \cdot MiF + (1-\alpha) \cdot (SiC \cdot NEvt \cdot MiF)] + (1-\beta) \\ Mdl &= \gamma \cdot [\beta \cdot (\alpha \cdot MiF + (1-\alpha) \cdot (SiC \cdot NEvt \cdot MiF)) + (1-\beta) \cdot (1- \\ &\quad ((\eta \cdot AiF + (1-\eta) \cdot (1-(SiC \cdot NEvt)) \cdot AiF)))] \\ Im &= \gamma \cdot Im_{norm} \end{aligned}$$

This equilibria describes the condition when individuals are experiencing an intense negative cognitive thought throughout time will eventually have their level immunity reduced to the lowest boundary of individuals' limit. This condition creates higher vulnerability towards the development of onset during the present of negative events. It also represents the conditions where individuals with high maladaptive inferential feedbacks and situational cues levels over prolong period tend to develop cognitive depressogenic thought. Simulation traces in Case #1 and #3 confirm this equilibrium condition.

### Condition # 2: $CdT=0$

Another special case of an equilibrium condition is when the *CdT* is zero. In this case, the following values are found:

$$\begin{aligned} CDi &= \alpha \cdot MiF \\ PtS &= \eta \cdot AiF \\ SrR &= \beta \cdot (\alpha \cdot MiF) \\ Mdl &= \gamma \cdot \beta \cdot (\alpha \cdot MiF) \cdot (1-\eta \cdot AiF) \\ Im &= \gamma \cdot Im_{norm} + (1-\gamma) \cdot Im_{norm} \end{aligned}$$

From this, it is an equilibrium, which would be considered a good condition since the stable individuals' immunity is describing people with a good mental condition (less vulnerable towards stressors). Having this, it shows that individuals with high adaptive inferential feedbacks and low situational cues tend to have a low cognitive depressogenic thought level even during prolong exposure towards stressors. All simulation traces from experiments (case #1, #2, and #3) confirm this condition. This condition is imperative to reduce the formation of potential relapse / recurrence caused by negative events.

### Condition # 3: $Hps = \tau \cdot CdT$

In this condition (if  $\tau=1$ ), the following values are found:

$$\begin{aligned} CDi &= \alpha \cdot MiF + (1-\alpha) \cdot (SiC \cdot Hps \cdot NEvt) \cdot MiF \\ PtS &= \eta \cdot AiF + (1-\eta) \cdot (1-(SiC \cdot NEvt \cdot HpS)) \cdot AiF \\ SrR &= \beta \cdot (\alpha \cdot MiF + (1-\alpha) \cdot (SiC \cdot Hps \cdot NEvt) \cdot MiF) + \\ &\quad (1-\beta) \cdot HpS \\ Mdl &= \gamma \cdot [\beta \cdot (\alpha \cdot MiF + (1-\alpha) \cdot (SiC \cdot Hps \cdot NEvt) \cdot MiF) + \\ &\quad (1-\beta) \cdot HpS \cdot (1-(\eta \cdot AiF + (1-\eta) \cdot (1- \\ &\quad (SiC \cdot NEvt \cdot HpS)) \cdot AiF))] \\ Im &= \gamma \cdot Im_{norm} + (1-\gamma) \cdot (1-HpS) \cdot Im_{norm} \end{aligned}$$

This equilibrium condition represents where the individuals remain constant in a cognitive depressogenic thought state over time points. If  $Hps > \tau \cdot CdT$ , this condition illustrates the individuals are progressing to have a positive cognitive thought and vice versa.

## Conclusion

In this paper, a model to investigate the phenomenon of the cognitive depressogenic thought has been developed. The proposed model is designed from several scientific findings in cognitive depressogenic thought and hopelessness. It provides a useful insight to understand the

dynamics of related concepts in individual's cognitive depressogenic thought, inferential feedbacks, and negative events. To this end, the model is presented in a dynamic model, to allow possible experimental settings for a variety of different conditions. Using a visual programming language, several numbers of simulation experiments under different parameter settings have been performed. Despite of validating the model will be carried out in future, these experimental results pointed out that the model is able to produce behaviour of different types of inferential feedback, and it is bear a resemblance of several results in related literature.

In addition, by a mathematical analysis, equilibria conditions of the model have been determined. This mathematical analysis is equally essential to reveal the occurrence of equilibrium conditions, primarily to illustrate the convergence and stable state of the model. Future work of this model will be specifically focus for potential integration with our existing relapse and recurrence model in unipolar depression. Having this model coupled, it will provide a better cognitive perspective on how cognitive depressogenic thought related to the recurrence and relapse in depression. Furthermore, it will promote a better way to formulate support in automated monitoring and health informatics systems.

### Acknowledgments

The preparation of this paper would not have been possible without the support, and endless efforts of Prof. Dr. Jan Treur and Dr. Michel Klein. The author is particularly pleasure to thank both of them for ideas, and refinement of this paper.

### References

- Abramson, L.Y., Alloy, L.B., Hogan, M.E., Whitehouse, W.G., Donovan, P., Rose, D.T., Panzarella, C., & Ranieri, D. (1999). Cognitive vulnerability to depression: Theory and evidence. *Journal of Cognitive Psychotherapy*, 13, 5-20.
- Abramson, L.Y., Metalsky, G.I., & Alloy, L.B. (1989). Hopelessness depression: a theory-based subtype of depression, *Psychol. Rev.* 96, pp. 358-372
- Alloy, L. B., Abramson, L. Y., Gibb, B. E., Crossfield, A. G., Pieracci, A. M., Spasojevic, J., & Steinberg, J. A. (2004). Developmental antecedents of cognitive vulnerability to depression: Review of findings from the cognitive vulnerability to depression project. *Journal of Cognitive Psychotherapy*, 18(2), 115-133.
- Alloy, L. B., Abramson, L. Y., Tashman, N. A., Berrebbi, D. S., Hogan, M. E., Whitehouse, W. G., et al. (2001). Developmental origins of cognitive vulnerability to depression: Parenting, cognitive, and inferential feedback styles of the parents of individuals at high and low cognitive risk for depression. *Cognitive Therapy and Research*, 25(4), 397-423.
- Beck, A.T. (1987). Cognitive models of depression, *Journal of Cognitive Psychotherapy* 1, pp. 5-37.
- Coyne, J.C (1990). Interpersonal process in depression. In: G.I. Keitner, Editor, *Depression and families: Impact and treatment*, American Psychiatric Press, Washington, DC , pp. 31-53.
- Crossfield, A. G., Alloy, L. B., Gibb, B. E., & Abramson, L. Y. (2002). The development of depressogenic cognitive styles: The role of negative childhood life events and parental inferential feedback. *Journal of Cognitive Psychotherapy*, 16(4), 487-502.
- DeFronzo R., Panzarella, C. & Butler, A.C. Attachment, support seeking, and adaptive feedback: Implications for psychological health (2001), *Cognitive and Behavioral Practice* 8, pp. 48-52
- Dobkin, R.D, Panzarella, C., J. Fernandez, Alloy, L.B., & Cascardi, M. (2004). Adaptive inferential feedback, depressogenic inferences, and depressed mood: A laboratory study of the expanded hopelessness theory of depression, *Cognitive Therapy and Research*, pp. 487-509.
- Heller, K. and Rook, K.S. (1997). Distinguishing the theoretical functions of social ties: Implications for support interventions. In: S. Duck, Editor, *Handbook of personal relationships: Theory, research, and interventions*, John Wiley and Sons, Chichester, England, pp. 649-670.
- Panzarella, C., & Alloy, L. B. (1995). Social support, hopelessness, and depression: An expanded hopelessness model. In L.B. Alloy (Chair), *The hopelessness theory of depression: New developments in theory and research*. 29<sup>th</sup> Annual Convention of the Association for Advancement of Behavior Therapy, Washington, DC.
- Panzarella, C., Alloy, L.B., & Whitehouse, W.G. (2006). Expanded hopelessness theory of depression: On the mechanisms by which social support protects against depression, *Cognitive Therapy and Research* 30 (3), pp. 307-33
- Roberts, J.E, & Gotlib I.H (1997), Social support and personality in depression: Implications from quantitative genetics. In: R. Pierce, B. Lakey, I.G. Sarason and B.R. Sarason, Editors, *Sourcebook of social support and personality*, Plenum Press, New York, pp. 187-214.
- Robinson, M. S., & Alloy, L. B. (2003). Negative cognitive styles and stress-reactive rumination interact to predict depression: A prospective study. *Cognitive Therapy & Research*, 27(3), 275-292.
- Segal, V.Z., Pearson, L.J., and Thase, M.E (2003). Challenges in Preventing Relapse in Major Depression: Report of a National Institute of Mental Health Workshop on State of the Science of Relapse Prevention in Major Depression. *Journal of Affective Disorders* 77, 97-108.
- Spasojevic, J., & Alloy, L. B. (2001). Rumination as a common mechanism relating depressive risk factors to depression. *Emotion*, 1(1), 25-37.