

## PHASES IN THE UNRAVELING OF THE SECRETS OF THE GEAR SYSTEM OF THE ANTIKYTHERA MECHANISM. <sup>1</sup>

Teun Koetsier

Department of Mathematics, Faculty of Science, Vrije Universiteit, De Boelelaan 1081, NL-1081HV, Amsterdam, The Netherlands. E-mail: [t.koetsier@few.vu.nl](mailto:t.koetsier@few.vu.nl)

### INTRODUCTION

Shortly before Easter of 1900 a party of Greek sponge fishers from the island of Syme near Rhodes returned from their normal fishing grounds near Tunisia. In the channels between the islands of Kythera and Crete they were driven off course by a gale and found shelter close to Kythera, near the barren island of Antikythera. After the storms had subsided the divers explored the shallow rock shelves below them on which they had dropped their anchor. At a depth of 42 meters they found a 50 meter long ship wreck containing a plainly visible pile of bronze and marble statues.

In November 1900 a difficult salvage operation started that lasted until the end of September 1901. Eight months after the end of the salvage operation, Spyridon Staïs, a prominent Greek archaeologist, discovered an inscription on one of the pieces of corroded bronze from the wreck in the National Museum in Athens. Traces of gear-wheels were clearly visible as well. The pieces turned out to be parts of a complicated mechanism. It is remarkable that this wasn't discovered earlier. Some uninteresting looking lumps may have only revealed their significance in the museum after they had cracked.

This was the beginning of an exciting story. The mechanism had obviously been a complicated astronomical instrument, a kind of astrolabe or a planetarium. However, what was it exactly? It took a long time before the first satisfactory answers could be given. With the completion of the reconstruction by Freeth *et al.*, published in 2006 in *Nature*, research on the mechanism has entered a new phase [6]. As a result we now basically know how the mechanism works. It is highly improbable that future research will lead to more than minor modifications in the reconstruction of the gearing system.

---

<sup>1</sup> This is the text of a lecture given at the International Symposium on the History of Machines and Mechanisms held in Tainan, Taiwan, Nov. 10 – 14, 2008.

See [http://www.ihms.ac.cn/news/\\_overlay/HMM2008.htm](http://www.ihms.ac.cn/news/_overlay/HMM2008.htm)

The symposium is one of the activities initiated by the Permanent Commission for the History of Mechanism and /machine Science of IFToMM (International Federation for the Promotion of Mechanism and Machine Science).

See: <http://130.15.85.212/indexa.html>

A modified version of the text will appear in

**Marco Ceccarelli *et al* (eds), *International Symposium on History of Machines and Mechanisms, Proceedings HMM 2008*, Springer Publishing Company, New York etc. 2008**

On the other hand, further investigation of the inscriptions may still yield surprising results, as the publication of [7] in 2008 proves.

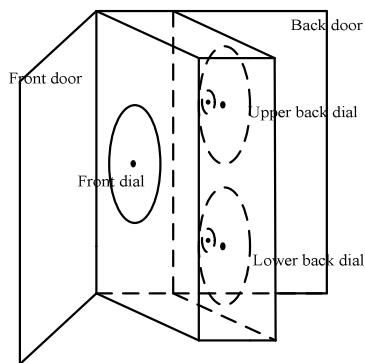
The publication in *Nature* in 2006 was the climax in an exciting development that I will describe below. Three phases can be distinguished. Phase 1 culminated in Price's reconstruction in 1974 [11]. Phase 2 culminated in the publication of Wright's reconstruction in the years 2003 through 2005 [18 - 22]. Phase 3 culminated in the publication by Freeth *et al.* in 2006 [6].

## PRICE'S RECONSTRUCTION

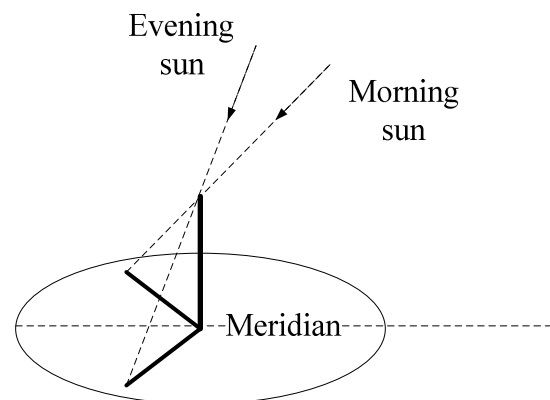
Although scholarly interest was immediately considerable, it was only in the 1950s, with the involvement of Derek de Solla Price (Yale), that the Antikythera mechanism began to draw public attention. In particular the article published by Price in June 1959 in *Scientific American* under the title 'An Ancient Greek Computer' had a considerable impact. Yet Price's *Scientific American* article raised more questions than it provided answers.

In 1971 there was a breakthrough. Price engaged the help of the Greek Atomic Energy Commission. The radiographer Charalambos Karakalos undertook the cumbersome work of preparing gamma-radiographs and fine x-radiographs. The radiographs were inspected visually. Karakalos and his wife Emily made counts of gear teeth. In 1974 Price published a definitive account of the results that had been achieved [11].

The fragments fitted together in such a way that Price assumed that the original mechanism had been in a rectangular box with a dial on the front of the mechanism in the middle of the rectangular front surface and two dials on the back of the mechanism. The two back dials each had a subsidiary dial. There were plates over the dials and Price conjectured that they were joined as doors (See Figure 1).



**Fig. 1.** Rough sketch of the case of the Antikythera mechanism with front and back doors open. The two back dials each had a subsidiary dial.



**Fig. 2.** A gnomon.

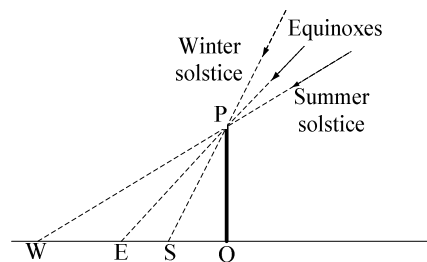
The mechanism was driven by means of a drive axle. Price gave a reconstruction of the gearing system. He identified the mechanism as a calendrical Sun and Moon computing system *ca.* 80 BCE. The date and the position of the Sun and the Moon in the Zodiac could be read off the front dial plate. A remarkable part of Price's reconstruction is a differential gear system with a large differential turntable in the centre. This was an amazing result because differential gears are conceptually sophisticated and their

occurrence in antiquity was a complete surprise. Below we will look at the details. First, however, we must turn our attention to Greek astronomy.

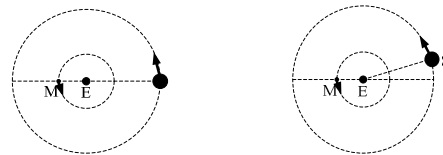
### GREEK ASTRONOMY 1: COUNTING DAYS, MONTHS AND YEARS, THE METONIC AND CALIPPIC CALENDARS

The behaviour of the celestial bodies is in many ways cyclical: the same phenomena repeat themselves with a certain period. Counting days is easy. Measuring the number of days in a month, for example a synodic month (also called a lunation: from Full Moon to Full Moon or from New Moon to New Moon) is less easy. Measuring the number of days in a year is difficult as well, although a simple instrument can help. According to Herodotus the Babylonians taught the Greeks the use of the gnomon (see Figure 2). The gnomon is merely a pole erected vertically on a horizontal plane. Its use is simple: on a sunny day one registers the behavior of the shadow of the pole.

By means of a gnomon the North-South direction can be found easily. One determines the direction of the shadow in the morning and in the afternoon at moments when the two shadows are equally long: The bisector of the two directions gives the direction of the meridian. The moment at which the shadow coincides with the meridian corresponds with the highest position of the Sun on that particular day. However, much more can be done with this simple instrument if we register the shadow corresponding to the highest position of the Sun in the course of the year (see Figure 3). This provides a way to measure the tropical year.



**Fig. 3.** PE is the bisector of the angle WPS



**Fig. 4.** Sun and Moon in opposition (left). One sidereal month later (right): the moon has completed a revolution about the earth. However, in the mean time the Sun has moved on: opposition is only reached after two more days, after a synodic month.

By means of the gnomon it is possible to establish the dates of the summer solstice (the longest day), the winter solstice (the shortest day) and the two equinoxes (day and night are equally long). Ancient astronomers were looking for ways to relate the length of a year and the length of a month. However, a synodic month is not equal to an integral number of days. And a tropical year is not equal either to an integral number of days, nor to an integral number of synodic months. The precise relation between these periods of time was a problem.

When one considers the motion of the Sun and the Moon not with respect to the earth but against the backdrop of the stars yet again other periodicities show up. Clearly the Sun participates in the rotation from east to west of the fixed stars: one full rotation takes exactly one day. However, the Sun also moves from west to east with respect to the fixed stars; this seems to be a circular motion whereby the Sun moves through twelve

constellations of stars. The lengths of the seasons determined by the Greek astronomers, however, make it clear that this latter motion is only approximately a uniform circular motion. The Greeks called the belt of twelve constellations of stars through which the Sun moves the Zodiac. For the Greeks, who introduced geometrical modeling in astronomy, the Zodiac corresponded to a big circle on the sphere of the fixed stars. There are other heavenly bodies moving against the background of the fixed stars: the Moon and the planets; they all seem to be moving from west to east. The actual period of the Moon's orbit as measured with respect to the Zodiac, is known as a *sidereal* month. Figure 4 illustrates that a sidereal month differs from a synodic month. It takes the Moon extra time after completing a sidereal month to catch up and return to the same position with respect to the Sun and complete a *synodic* month.

Hipparchus discovered that the length of the year determined by the four seasons, the tropical year, differs slightly from the sidereal year, determined by the position of the Sun against the backdrop of the stars. This is his famous discovery of the precession of the equinoxes. It is so called because over the years the position of the equinoxes changes very slowly relative to the stars. Hipparchus introduced an important change in the description of the heavens: he separated the Zodiac from the stars, coupled the Zodiac to the tropical year and as a result of this he had to accept the fact that the Zodiac slowly moves with respect to the stars. This implies that we must, strictly speaking, distinguish the tropical year from the sidereal year and the tropical month from the sidereal month. Below we will not do this because the precession of the equinoxes is extremely slow (one rotation in about 25770 years).

In the 5th century BCE the famous Athenian astronomer Meton defined the cycle that was afterwards called the *Metonic cycle* in which 19 tropical years are made to correspond with 235 synodic months (or 254 sidereal months). In the cycle the 235 synodic months (or 254 sidereal months) represent 6940 days. The basic idea is that 19 is the smallest number of tropical years that is close to an integral number of both synodic and sidereal months. The cycle implicitly gives the Metonic length of the year: 6940 divided by 19 is  $365 \frac{5}{19}$  days. To keep a 12-month lunar year in pace with the tropical year, a 13th month must be added seven times during the nineteen-year period. Yet the 6,940 days of the Metonic cycle of 19 years happen to exceed 235 lunations by almost a third of a day. A century later Callippus, an associate of Aristotle, multiplied the 19-year cycle by 4 and then dropped 1 day from the last 19-year cycle. Thus he constructed a cycle of 76 years that contains 940 lunations and 27,759 days. It has been called the *Callippic cycle* after him. It leads to a year of exactly  $365 \frac{1}{4}$  days, which is as we know more accurate than the Metonic length of the year. The Callippic calendar was used for astronomical dating by many of the Hellenistic astronomers. Hipparchus used it and so did Ptolemy.

## **MECHANICAL MODELING OF ASTRONOMICAL PHENOMENA**

In 1983 the Science Museum in London acquired four fragments of a Byzantine portable sundial with a geared calendar dating from between the fourth and the seventh century CE. This was a spectacular find because it showed that between the Antikythera mechanism and al-Biruni's *Book on the Full Comprehensiveness of the Possible Methods for Constructing the Astrolabe* from about 1000 CE geared planetaria or calendars had been built. The mechanism is discussed in detail in [14]. The gearing of the Byzantine sundial calendar resembled that of a calendrical device described by al-Biruni in his book. Gearing similar to that described by al-Biruni is found in a Persian astrolabe dating from 1221/2 that is now in the Museum of Science in Oxford (Inventory number CCA 5).

The earliest Latin example of gearing that served the same purpose occurs in an astrolabe from about 1300 CE, now in the Science Museum in London (Inventory number 1880-32). It seems probable that the Antikythera mechanism is part of a tradition of making representations of the motions of the heavenly bodies by means of gear trains. This tradition started in antiquity and continued in the Byzantine Empire and in Islamic culture.

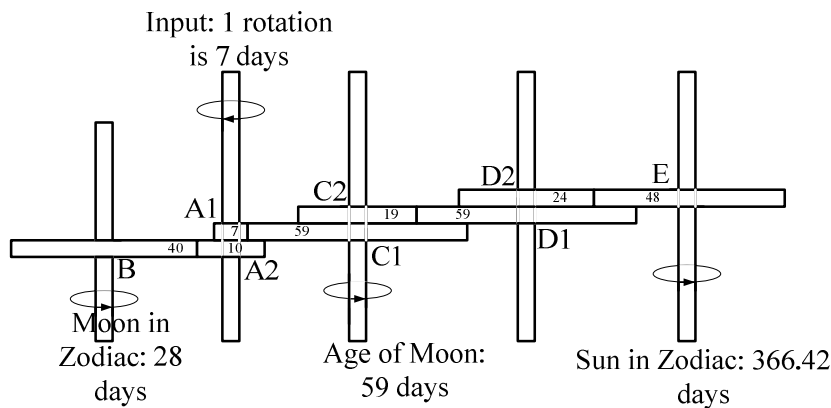
The existence of this tradition in Antiquity is confirmed by a few other sources. I will give one example. Cicero spent two years on Rhodes from 79 to 77 BCE with the stoic philosopher Posidonios of Apamea. In Cicero's *De natura deorum* II, he discusses the views of thinkers who doubt that the universe is guided by reason. The text says (Rackham's translation quoted by Price, [11] p. 57):

“Suppose a traveler to carry into Scythia or Britain the orrery recently constructed by our friend Posidonius, which at each revolution reproduces the same motions of the Sun, the Moon and the five planets that take place in the heavens every day and night, would any single native doubt that this orrery was the work of a rational being? These thinkers however raise doubts about the world itself from which all things arise and have their being, and debate whether it is the product of chance or necessity of some sort, or of divine reason or intelligence; they think more highly of the achievement of Archimedes in making a model of the revolutions of the firmament, than of that of nature in creating them, although the perfection of the original shows a craftsmanship many times as great as does the counterfeit.”  
(*De natura deorum* II,88)

This quotation shows that in Antiquity planetaria existed. As an illustration I will describe the gear trains of an instrument described by al-Biruni which displays the Age of the Moon and the positions of the Moon and the Sun in the Zodiac in three separate displays (see Figure 5). An axle driven by hand is rotated once a week. It carries two pinions, A1 with 7 and A2 with 10 teeth. The wheel with 10 teeth drives a wheel B1 with 40 teeth giving the position of the Moon in the Zodiac. The wheel A1 with 7 teeth drives a wheel C1 with 59 teeth. On the axle of C1 there is C2 which drives a wheel D1 with 24 teeth. On the axle of D1 there is D2 with 24 teeth which drives E1 with 48 teeth representing the position of the sun in the Zodiac.

Clearly, one rotation of the input axle represents a week of 7 days. 4 weeks correspond to one rotation of the B-axle representing a month of 28 days. The wheel with 59 teeth on the C-axle turns once in 59 days. It represents the Age of the Moon, which is important in the Islamic calendar. The Islamic calendar is based on a lunar year of 12 months in which months with a length of 30 and 29 days alternate. The Age of the Moon, measured from the time of the New Moon, tells us where we are in this cyclical process which has a two-month period of 59 days.

The wheel with 48 teeth on the E-axle turns once in  $(48/24) \cdot (59/19) \cdot (59/7) = 52.35$  weeks = 366.42 days. As a matter of interest, al-Biruni elsewhere, in his *Astrology*, gives 365.24 days for the length of the year (Cf. [14]).



**Fig. 5.** Gear system of al-Biruni's calendrical device (Based on [14], Figure 12)

As we shall see, this idea of modeling cyclical astronomical phenomena by means of gear-wheels goes back to antiquity. The gear system of the Antikythera mechanism is similar but much more sophisticated.

### PRICE'S RECONSTRUCTION: GENERAL REMARKS

Before turning to the gear system of the Antikythera mechanism I will summarize aspects of Price's reconstruction. The front dial plate contains two annuli. The inner annulus is immovably fixed in position. It undoubtedly carried in  $30^\circ$  intervals the Greek names of the signs of the zodiac proceeding clockwise. The word  $\chi\eta\lambda\alpha\iota$  (chelai, the claws of the scorpion), the name of the sign nowadays called Libra, is clearly visible in one of the intervals. The movable outer annulus must have carried the 12 names of the 12 months in the Graeco-Egyptian year. The name of the 9th month  $\Pi\alpha\chi\omega\kappa\eta\iota$  = pachon is still visible. This year consisted of 12 periods of 30 days followed by a period of 5 days without adjustment for leap years. Because the tropical year is slightly longer, it is understandable that the outer annulus was made movable. The modern calendar corrects the asynchronicity of the 365 calendar years and the  $365 \frac{1}{4}$  tropical years by means of a leap year every four years. In the Antikythera mechanism the outer annulus had to be moved once every four years over  $1/365$  of a turn in an anti-clockwise direction.

The fragments show that on the back of the rectangular mechanism there was a plate with two dials. Each of the two back dials consists of a central plate with a 44.3 mm radius surrounded by a series of annuli. Price clearly discerned four annuli in the upper back dial (held together by a bridge) and three (held together by a bridge) in the lower dial. In the upper dial Price saw something that looked like a dial pointer, which was 55 mm long (and may have been longer originally). The lower back dial has a fixed and inscribed outer limb. Price thought that it was unlikely that there was a fourth annulus in the lower dial because of the presence of the outer limb. He could not tell whether the upper dial had an outer limb as well.

Price had considerable difficulties with the inscriptions. The upper back dial is heavily inscribed but Price could not read the inscriptions on it. The lower back dial had comparatively few inscriptions. Only a small piece of the back door is extant. Yet, because of the mirror inscription as a result of the huge pressure that the mechanism experienced for centuries, part of the inscription on the lower half of the back door was somewhat legible. See [11], p. 50. The Metonic and the Callipic cycles are mentioned. The front door inscription was not sufficiently legible.

Then there are *parapegma* inscriptions. A *parapegma* is a list of dates – with holes for placing a marker pin – of seasonally regular weather changes, first and last appearances of stars or constellations of stars at sunrise or sunset. They were composed for centuries in antiquity.

In Price's reconstruction the front dial showed the *mean* position of the Moon and the Sun with respect to the Zodiac. If the movable calendar annulus was given the right position, the future tropical mean positions of the Moon and the Sun could be calculated. On the basis of his reconstruction of the gear system Price came to the conclusion that the lower back dial counted the synodic months and the lunar years.

Price rejected the possibility that the upper back dial could have displayed the period of the planets or the 223-month eclipse cycle which is referred to on one of the instrument door panels ([11], p. 44). In his rejection of the possibility that the dial displayed the eclipse cycle he was wrong, as will become apparent in the relevant section in the part on the reconstruction by Freeth *et al.* The tooth count led Price to conclude that the main part of the upper back dial corresponded to one revolution approximately every four tropical years. He did not succeed in drawing further firm conclusions.

### **PRICE'S RECONSTRUCTION: THE GEARING SYSTEM: THE GEAR TRAINS DRIVING THE SUN AND MOON POSITION WHEELS.**

Price gave the reconstruction of the gear trains shown in Figure 6. Price assumed that the crown wheel with which the mechanism was driven had 45 teeth and that the main drive wheel B1, driven by the crown wheel, had 225 teeth. These numbers do not have any astronomical significance. On the shaft connected to the main drive wheel B1 there is wheel B2 (with 64 teeth), which drives C1 (with 38 teeth) which has on its axle C2 (with 48 teeth), which drives D1 (with 24 teeth), which has on its axle D2 (with 127 teeth), which drives B4 (with 32 teeth). B4 is on a shaft inside the axle carrying B1 and B2. Consider one revolution of the main drive wheel. This produces  $n$  revolutions of the inner shaft with  $n = (64/38) \cdot (48/24) \cdot (127/32) = 254/19$ . So 19 revolutions of the main drive wheel lead to 254 revolutions of the inner shaft.

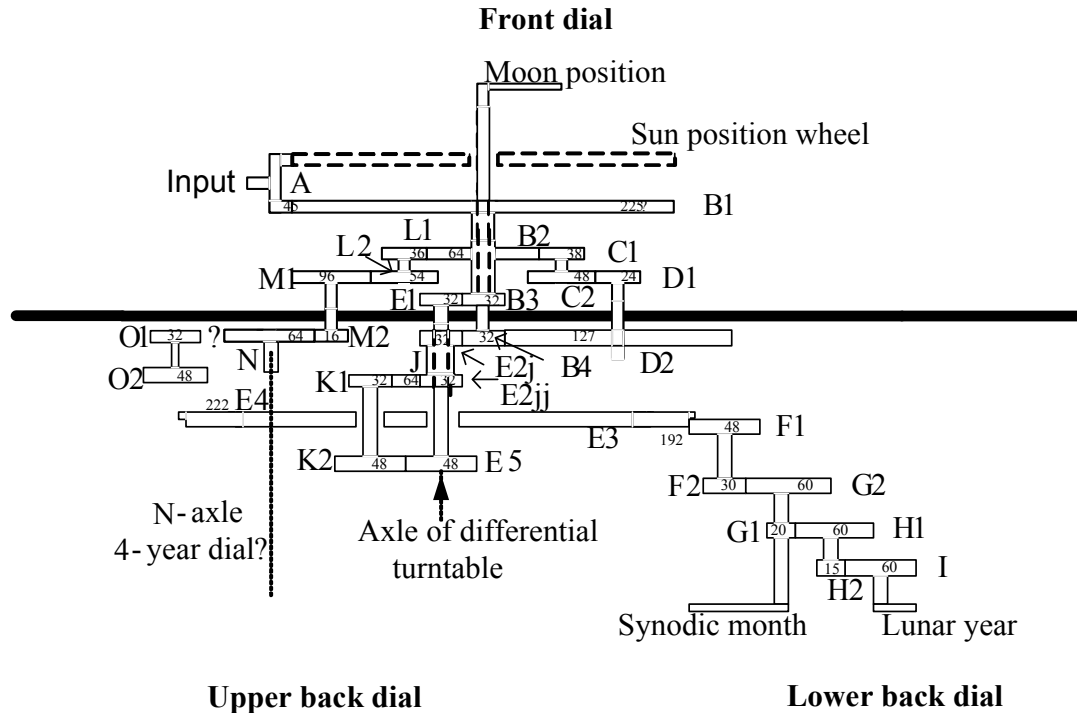
In the Metonic cycle 19 tropical years (consisting of 6940 days) correspond to 254 sidereal revolutions of the Moon (of about  $27 \frac{1}{3}$  days). Thus a "Sun position wheel" of the same size as the drive wheel, rotating, however, in the opposite direction, and a "Moon position wheel" connected to the inner shaft would represent the tropical years and sidereal months of the Metonic cycle. The two position wheels would represent the positions of the Moon and the Sun with respect to the Earth.

### **PRICE'S RECONSTRUCTION: THE GEAR TRAINS CONNECTING TO THE LOWER BACK DIAL**

The fragments show that there were two dials on the back of the rectangular mechanism. In Price's reconstruction the upper back dial corresponded to the gear train at the bottom left of Figure 6 (axles M, N and O), and the lower back dial corresponded to the gear train at the bottom right of Figure 6 (axles F, G, H and I). Let us look at the bottom right gear trains.

A *sidereal* month has a duration of about  $27 \frac{1}{3}$  days. The *synodic* month, the period based on the appearance of the Moon from the earth, has a duration of about  $29 \frac{1}{2}$  days. The rotating inner shaft carrying B4 corresponds to the sidereal month. An axle corresponding to the synodic months needs to make 235 revolutions during the 19 tropical years of the Metonic cycle. In Price's reconstruction the bottom right part in Figure 5 yields an axle that makes 235 revolutions. Price assumes that in the Antikythera mechanism the 235

was obtained by subtracting 19 from 254 by means of a differential gear. The possibility that the clearly visible large central gear-wheel had been a differential turntable was already mentioned in Price's 1959 paper in *Scientific American*. In 1974 Price provided the details. He proposed that the differential system was connected to the lower back dial where full rotations of the two pointers would correspond to a synodic month and a lunar year (of 12 synodic months).



**Fig. 6.** Price's reconstruction of the gear system ([11], p. 43).

**PRICE'S RECONSTRUCTION: THE DIFFERENTIAL GEAR.**

Consider Figure 8. A straight bar  $W_1$  can rotate about a centre  $O$ . A wheel  $W_2$  can rotate about  $O$  and  $W_2$  drives another wheel  $W_3$  that can rotate about a centre on the bar  $W_1$ . System  $W_0$  is the system of reference at rest, the World. The radius of the wheels  $W_i$  is equal to  $r_i$ .

We use the following notation. The angular velocity of system  $W_i$  with respect to System  $W_j$  is  $\omega_{ij}$ . The anticlockwise direction is positive. Consider the point where the wheels  $W_2$  and  $W_3$  touch. It is a point of  $W_2$  and as such its velocity with respect to the World  $W_0$  is

$$r_2 \cdot \omega_{20}$$

It is a point of  $W_3$  as well and as such its velocity with respect to the World  $W_0$  is

$$r_2 \cdot \omega_{10} - r_3 \cdot \omega_{31}$$

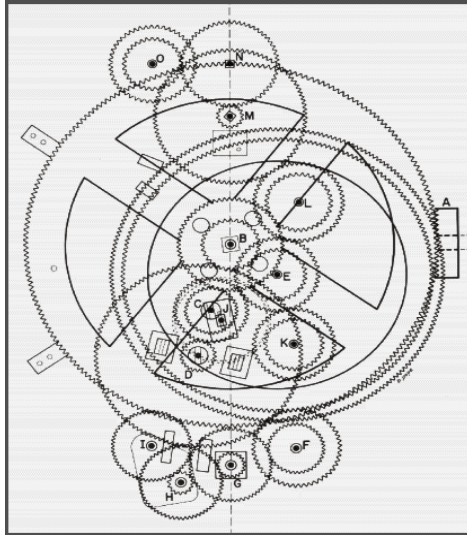
Because  $W_2$  drives  $W_3$  without slipping these two velocities are equal. This yields an important equation:

$$\omega_{31} = (r_2 / r_3) \cdot (\omega_{10} - \omega_{20}) \text{ or } \omega_{10} = (r_3 / r_2) \omega_{31} + \omega_{20} \tag{1}$$

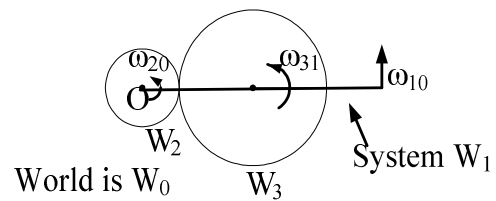
The effect of the rotation  $\omega_{10}$  is that from the point of view of the rotating bar  $W_1$  it merely slows down the rotation of the driving wheel  $W_2$ . This means that if, instead of

the short train  $W_2 - W_3$ , we consider the train  $W_2 - W_3 - W_4 - \dots - W_n$  of wheels, we get the formula

$$\omega_{n1} = (-1)^{n+1} \cdot (r_2/r_n) \cdot (\omega_{10} - \omega_{20}) \text{ or } \omega_{10} = (-1)^{n+1} (r_n/r_2)\omega_{n1} + \omega_{20}. \quad (2)$$



**Fig. 7.** Top view of the wheelwork in Price's reconstruction ([11], p. 37)



**Fig. 8.** Rotating gear chain

Now consider Price's gear trains. Suppose the inner B-shaft makes 254 revolutions per unit of time. Then the wheel B4 makes 254 revolutions per unit of time, which means that the wheels E2j and E2jj make 254 revolutions as well. In the same unit of time E1 and E5 driven by B3 make 19 revolutions.

We now consider gear trains E2jj, J and K1, on the one hand, and E5 and K2, on the other hand. Their inputs are, respectively, +254 and -19 revolutions per unit of time. Nota bene: the opposite signs are important! The output wheels K1 and K2, are fixed to and rotate about the same axle K. If the two gear chains would not rotate about the common axle of the input wheels, this would be impossible. However, they are allowed to rotate and in fact drive the differential turntable E4/E3. E4 is a disc, E3 is smaller annulus fixed to the turntable. Suppose its angular velocity is  $\omega_{table}$ . Applying the formula (2) for a rotating gear chain twice, we get:

$$\omega_{table} = -\omega_K + 254 \quad \text{and} \quad \omega_{table} = \omega_K - 19$$

So  $\omega_{table} = (254-19)/2=235/2$ . This means that the G axle makes  $(192/48).(30/60).(235/2) = 235$  revolutions per unit of time.

### **BROMLEY AND WRIGHT REFUTE PRICE**

In the first half of the 1980s Michael Wright developed serious doubts about Price's reconstruction which he shared with Alan Bromley ([1], p. 26). In 1994 they had obtained permission from the National Museum in Athens and Wright had build a tomograph at home which they used with an X-ray tube in the National Museum in Athens to make some 700 images of the fragments. Bromley took the data with him to Australia and fell

ill. Bromley died in 2002. The plan was that Bromley would have the radiographic plates scanned and digitized but he never achieved this. At the end of 2000 Wright succeeded in retrieving most of the material. Until autumn 2003 he analyzed the plates by peering at them through a magnifier. Only in 2003 he succeeded in having the plates scanned. Bromley and Wright first of all showed beyond reasonable doubt that Price's reconstruction of the gear system was seriously flawed. In particular the spectacular differential gear was never there. Its existence could even be refuted on the basis of Karakalos's radiographs. It became clear that Price had been carried away by the assumption of the existence of a differential gear. It explained the existence of the large turntable and it enabled him to make sense of the lower back dial, but careful consideration revealed serious problems related to Price's assumption that the big central gear-wheel had been a differential turntable. Price thought that he needed the differential gear in order to get a wheel that makes 235 rotations while the outer axle B and the inner axle B, respectively, make 19 and 254 rotations. The differential gear does this by subtracting 19 from 254. Bromley and Wright showed that there are much easier ways to solve this particular problem by using plain fixed axle gear without using wheels of extraordinary size ([18], p. 273). For example, if we put a wheel D3 with 20 teeth on axle D engaging a wheel Y1 with 32 teeth on an a new axle Y, a wheel on Y2 with 94 teeth engaging a wheel Z1 with 16 teeth on an axle Z, this axle Z gives us the synodic months, as  $B2-C1+C2-D1+D3-Y1+Y2-Z1$  gives the ratio  $(64/38).(48/24).(20/32).(94/16) = 235/19$ .

Bromley and Wright took this argument even further. A display of the synodic month could have been added to the front dial without any extra wheels. In other words, in Price's reconstruction a highly complicated mechanism plus an extra dial are used to do something that can actually be done quite simply. There is more, however. In Price's reconstruction the system is driven from the slow-moving end of the train. This means that relatively high loads develop in the chain. This point was already made in the 1980s by Wright ( Cf. [1], p. 26) and by Zeeman in [23]. Those who built models of Price's reconstruction, even though they used modern wheelwork, experienced problems as a result. They found it hard to make their models work. G. White even claimed that Price's reconstruction could not have worked at all [13]. In his paper White proposes changes in Price's reconstruction that leave its basic structure intact.

Clearly Price's reconstruction was in serious trouble. The tomograms supplied the final and most convincing argument against Price's reconstruction. A detailed description of the argument is to be found in [18], pp. 275-277. Consider the wheels K2 and E5 in Figure 6. Karakalos noticed the double thickness of both wheels. He saw K2 definitely as a double wheel and he counted more teeth on E5 (50-52) than on K2 (48 or 51). Price chose to overrule Karakalos' observations ([11], p. 34) because "the apparent purpose is simply to provide a 1/1 gear ratio". Distortion and corrosion, said Price, hide the fact that there are two gear-wheels of equal size, each with 48 teeth. Wright had another good look and saw double wheels.

Sometimes Price had to alter Karakalos's results drastically in order to make them fit. Karakalos counted 54 or 55 teeth on gear-wheel G2, but Price needed 60 to make the mechanism fit his interpretation. So 60 it became ([11], p.35). Similarly in the case of wheel F1. Karakalos had counted 54 teeth, but Price needed 48 teeth, and so it became 48.

Of course, when the numbers teeth of each gear-wheel are counted on the basis of radiographs of fragments, there are various potential sources of error. Yet Wright convincingly argues that Price definitely allowed himself too much latitude ([18], pp.

278-279). Price seems not to have counted the teeth himself but to have taken the figures offered by Karakalos and altered them to suit his model.

Moreover, the axles E, B and D lie in a triangular pattern. The tomographic plates do not show E2j, B4 and D2 engaged as Price suggested. The images show that D2 is engaged directly with a wheel on axle E and another wheel on E engages B4. The two wheels on axle E both seemed to have 32 teeth ([17] p. 83).

With good reason Price himself had called the differential gear the most spectacular part of his reconstruction ([11], p. 44). Unfortunately that part was wrong.

Bromley and Wright had to abandon the central element of Price's reconstruction, the differential gear. In the end Wright came up with a new reconstruction.

## **COMPETITION**

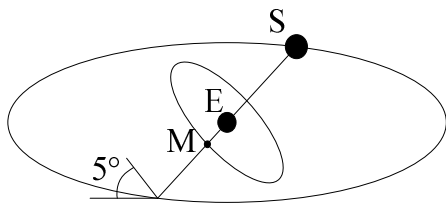
Only at the end of 2003, twenty years after he developed his first doubts about Price's reconstruction, Wright had the tomograms that had been made in 1994 scanned and he had the software for viewing and inspecting them. Things had been moving very slowly indeed. At the same time others had become interested in the secrets of the gear system of the Antikythera mechanism. In 2000 Mike Edmunds and Philip Morgan wrote a paper in which they discussed speculative planetary mechanisms that could have been part of the wheelwork of the Antikythera mechanism [3]. In 2002 Tony Freeth, mathematician and documentary film maker in London, published two papers on the mechanism ([4], [5]). In his papers Freeth severely criticized Price's reconstruction and he advocated a novel approach to the questions involving the engaging the most sophisticated recent technology. These early papers do not contain new answers to the questions. At the time Michael Wright was still undoubtedly the number one expert on the Antikythera mechanism in the world. However, change was in the air. As we shall see below, Edmunds and Freeth maintained their interest in the mechanism. Before we can discuss the ensuing developments we need to have another look at Greek astronomy.

## **GREEK ASTRONOMY 2: ECLIPSES AND THE SAROS CYCLE.**

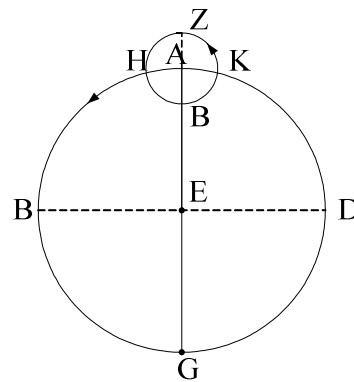
The Babylonians had a great interest in eclipses. They recorded them and they studied them. They knew, for example, that in order to have a lunar eclipse a Full Moon is needed and that for a solar eclipse a New Moon is needed. Some time before 575 BCE they discovered that the pattern of lunar eclipses repeated itself after 223 synodic months. This means that if there are records of the eclipses that occurred in a past cycle, we can predict eclipses. Because solar eclipses are only visible locally the precise prediction of solar eclipses is difficult. The Babylonians realized that the cycle yielded potential solar eclipses, but no certainty of solar eclipses. This period of 223 synodic months is now called the *Saros cycle*. The ancient astronomers called it the *Periodic* ([12], p. 175) The name *Saros* was coined by Sir Edmund Halley. It has no significance related to Antiquity. The Saros cycle corresponds to 6585 1/3 days. In order to obtain a period with an integral number of days astronomers before Hipparchus tripled the *Periodic* and obtained a period of 19756 days which they called *Exeligmos*.

The Greeks used the astronomical data of the Babylonians and they adopted their approach, but they added the element of geometrical modeling, which greatly advanced the understanding of the phenomena. They realized that the Moon, the Sun and the Earth could be considered as large spherical bodies. In addition they realized that, for an eclipse to occur, the Sun, the Moon and the Earth must be collinear. A lunar eclipse will only occur at Full Moon: the Sun and the Moon must be in *opposition*. A solar eclipse will only occur at New Moon: the Sun and the Moon must be on the same side of the Earth;

they must be in *conjunction*. However, a situation of *syzygy* (opposition or conjunction) is not enough for the centers of the three bodies to be collinear. This is because the plane in which the Moon rotates does not coincide with the plane of the Sun (see Figure 9). The angle between the two planes is approximately 5 degrees. The points of intersection of the orbit of the Moon with the ecliptic are called nodes. An eclipse can only occur when the Moon is in or close to a node. Actually the fact that the ecliptic and the orbital plane of the Moon do not coincide is clearly visible in the sky. An observer who watches the Moon and the Sun in the course of time will notice that once every synodic month the Moon seems to overtake the Sun (see Figure 4). This usually happens either above the Sun or below the Sun.

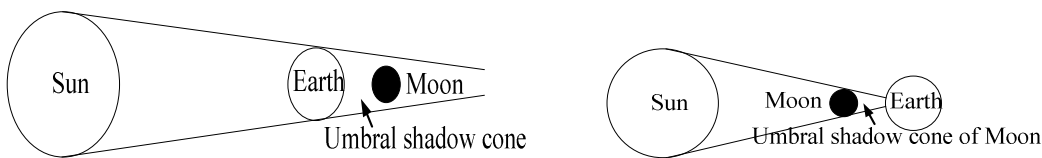


**Fig.9.** A lunar eclipse occurs when the Moon and the Sun are in opposition and the Moon is in or sufficiently close to the plane of rotation of the Sun.



**Fig. 10.** Hipparchus' epicycle model

In addition to the Sun and the Moon being in opposition or conjunction and the Moon being in a node one more condition must be fulfilled for a solar eclipse to occur. For a total eclipse of the Sun it is necessary that the Moon is in its perigee, i.e. in the point of its orbit where it is closest to the earth. If the Moon is close to the earth and in a node in conjunction with the Sun its conical umbral shadow, consisting of all those points not reached by any sunlight, will touch the surface of the earth. There we can see a total solar eclipse.



**Fig. 11.** Total lunar eclipse (visible everywhere on the right side of the earth) and a total solar eclipse (only visible locally)

Because of the difference in size between the Moon and the earth there is a major difference between solar and lunar eclipses, which is particularly important if one wants to predict eclipses, namely that during a lunar eclipse the entire Moon is covered by the umbral shadow of the earth, while during a solar eclipse the umbral shadow of the Moon falls only on a small part of the earth (see Figure 11). This means that the prediction of the visibility of a solar eclipse must take the observer's position on earth into account. The Saros cycle can be understood in terms of the Greek geometrical way of looking at the celestial phenomena. The two necessary conditions for an eclipse, viz. opposition or conjunction and the Moon being in a node, correspond to two cyclical phenomena:

i) The *synodic month* (New Moon to New Moon or Full Moon to Full Moon) of 29.5306 days.

ii) The *draconitic or draconic month* of 27.2122 days, which is the time the Moon needs to return to the same node. The draconic month differs from the sidereal month, because the nodes move. The line of intersection of the two orbital planes of Moon and Sun rotates slowly backward because the plane of the Moon does so.

A period of 223 synodic months is nearly equal to 242 draconic months. Moreover this period is also approximately equal to 239 anomalistic months (the time the Moon needs to go from perigee to perigee). This period of approximately 18 years, 11 days and 8 hours is obviously exactly the *Saros cycle*.

## HIPPARCHUS

From the period between 350 BCE and the year 0 many Babylonian astronomical cuneiform tablets are extant. They contain calculations and predictions concerning the phases of the Moon, the positions of planets etc. This was an arithmetic tradition in astronomy which kept a close track of the phenomena and differed from the more speculative tradition in which Eudoxus and Apollonius were working. These two great Greek mathematicians developed kinematical models of astronomical phenomena, but unlike the Babylonians they did not go beyond a qualitative comparison between the model and the phenomena. In this respect Hipparchus (about 150 BCE) represents a revolution. Hipparchus was familiar with Greek geometry and with Babylonian observations. As far as we know he was the first to try to really adapt the models to the actual, observed data.

Consider the epicycle model in Figure 10. Two circles are involved: the *epicycle* and the *deferent*. The *epicycle* ZHBK, or rather its centre, moves on the circle ABGD with centre E. This circle ABGD is called the *deferent*. The body moves on the epicycle ZHBK. It is quite obvious that seen from the point of view of the terrestrial observer the composition of these two uniform rotations is non-uniform. Suppose the epicycle moves in the direction from A to B. If the body on the epicycle is in the position K it appears to lag behind, if it is in H it appears to move faster than the epicycle.

In Hipparchus' model for the motion of the Sun the angular velocity corresponding to the epicycle (the anomalous motion) is equal to the angular velocity corresponding to the deferent (the motion of the Mean Sun). This means the sidereal year (return to the same fixed star) is equal to the anomalistic year (return to the same velocity). The anomaly is the phenomenon of the deviation from the uniform rotation. The anomalistic year is, for example, the time it takes between two moments of minimal angular velocity.

This model for the motion of the Sun can be rather simple because the Mean Sun and the anomaly have periods that are sufficiently similar for the difference not to be easily noticeable.

Unfortunately the motion of the Moon is more complex. Hipparchus used exactly the same model but the two periods are unequal: the period of the anomaly, the anomalistic month is larger than the sidereal month. In other words the epicyclic angular velocity is less than the velocity of the Mean Moon. Against the backdrop of the Zodiac the Moon moves at a velocity that fluctuates around a mean of some 13 degrees per day. As a result, the Moon moves back and forth over a distance of 6 degrees either way. The period of this fluctuation is the anomalistic month. A familiar method in Antiquity uses an anomalistic month of  $248/9$  days ([8]). Clearly this anomalistic month is equal to the period from perigee to perigee. It is also the period of time between two moments of minimum velocity as seen from the Earth.

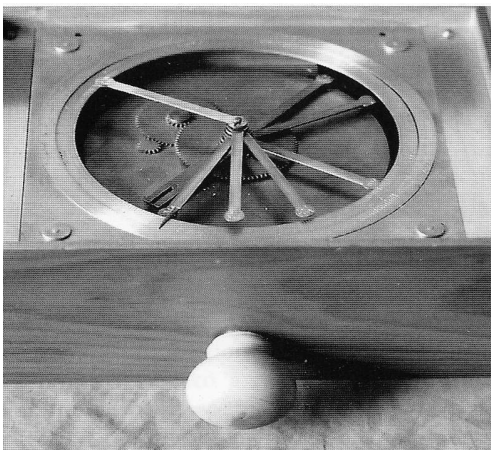
Conclusion: the motion of the Moon in Hipparchus' model is the combination of a uniform rotation with a period of one sidereal month and a sinusoidal back and forth motion with an amplitude of 6 degrees and a period somewhat greater than a sidereal month. This means that when the mean motion in longitude completes 360 degrees the mean motion in anomaly still has roughly 3 degrees to go.

For the calculations it is important to realize that the Moon is large and has a considerable daily parallax of almost twice its own diameter: observations by different observers are different. The most suitable observations to be used as data are observations of lunar eclipses. They take place at Full Moon when the Sun and the Moon are diametrically opposed. The longitude of the Sun at the exact moment of the eclipse can be taken from the table of the longitude of the Sun (made on the basis of the theory of the Sun) and  $180^\circ$  is added.

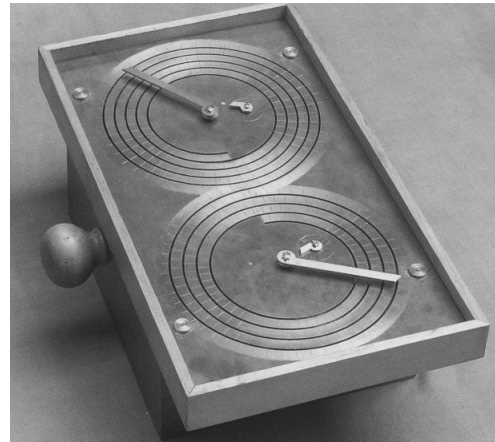
### WRIGHT'S RECONSTRUCTION 1

In the course of time Wright correctly identified all visible gear-wheels and counted the number of teeth on each gear-wheel.

Only the simple parts of Price's reconstruction were still standing after Wright's criticism. The assumption that on the front dial the positions of the Sun and the Moon were represented remained untouched by the criticism. Yet the precise manner in which this happened had to be corrected. In Price's reconstruction wheel D2 drove wheel B4 on the central axle. Wright discovered that this happened indirectly via two wheels on the E axle (wheels that Price used for the differential gear). The only effect of these two wheels was in Wright's reconstruction the reversal of the direction of rotation of the Moon position pointer. This made Price's Sun position wheel superfluous because the Sun position pointer received the same motion as the drive wheel B1. Parts of the L-M-N gear train leading to the upper back dial and the E-F-G-H-I gear train leading to the lower back dial were also correct.



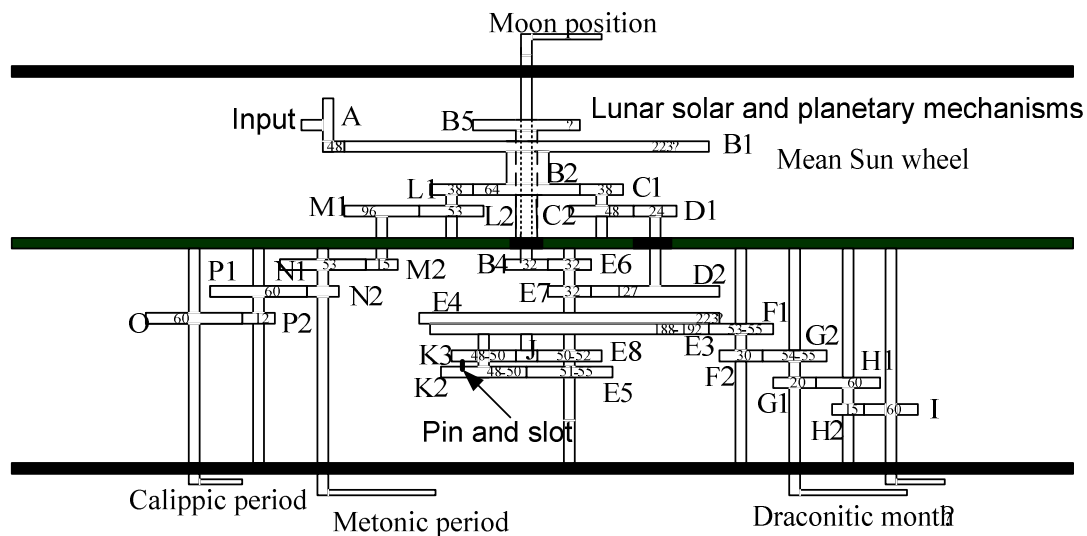
**Fig. 12.** Wright's model of the front dial including a display of the motion of the planets [18]



**Fig. 13.** Wright's 2005 reconstruction of the back-dials of the Antikythera mechanism [20]

Wright made sense of the upper back dial: in his reconstruction the main pointer counts the months in the Metonic cycle. The Metonic cycle of 19 tropical years is one of the

well-known astronomical cycles from Antiquity. In Wright's reconstruction the subsidiary dial tells us where we are in the Calippic cycle of 76 years, which consists of 4 Metonic cycles.



**Fig. 14.** Wright's reconstruction [21].

Wright had observed that what he called the Mean Sun Wheel (B1 in Figures 6 and 14) carried a structure and that the central boss around which it turned was stationary and carried a wheel (B5 connected to the base plate of the mechanism); so there was an epicyclic mechanism going round at the rate of the Mean Sun. This could easily have generated the motion of the inferior planets. Moreover there was the observation that Fragment C (front dial) does not join Fragment A (frame plate with all the gearing), which leaves room for further gearing representing the motion of the superior planets. Wright showed that the mechanism may indeed very well have included a display of the motions of the Superior Planets, Mars, Jupiter and Saturn by building a working model of the resulting conjectural design in which the Moon and the Sun moved in accordance with Hipparchus' theories and the five planets in accordance with the epicyclic theory prevalent at the time ([16] & [17]).<sup>2</sup> It is part of Wright's methodology that he systematically constructs models of the gear chains that he observes. He preferably uses very simple tools of the kind that would have been available in Antiquity. The planetarium display he has built in this way for the Antikythera mechanism is more than mere speculation.

Wright drew the provisional conclusion that the mechanism that replaced the differential gear drove a pointer on the lower back dial with a **rotational** period equal to one draconitic month. He drew the conclusion that the lower back dial **functioned** to predict eclipses. See [18] and [20].

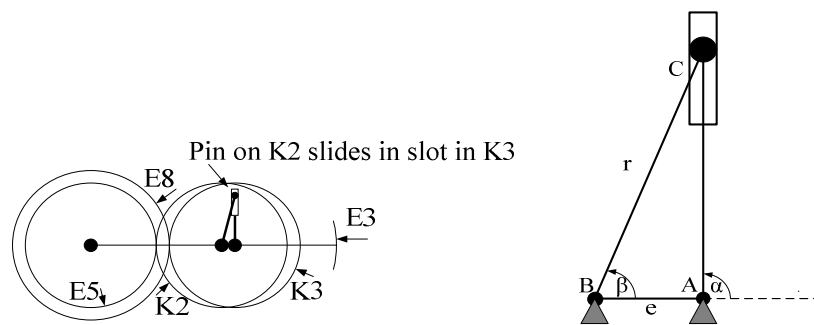
Wright analyzed the geometry of the remaining fragments of the two back dials. He noticed that they did not consist of concentric circles but of continuous spirals of five and four turns, respectively on the upper and the lower back dial ([20], p. 59).

<sup>2</sup> Price suggested this line of research in [11], p. 28. Wright was the first to develop the idea seriously, but others worked on it as well. See [3] and [5].

As for the function of the upper back dial Wright discovered that one revolution of the main pointer represented 47 months with a scale laid out as a five turn spiral containing 47 divisions in each turn. It represents the 235 months ( $235 = 5 \text{ times } 47$ ) of the Metonic cycle. He suggested, moreover, that the subsidiary dial indicated in which of the four Metonic cycles one was that make up a 76-year Calippic cycle [21].

### WRIGHT'S RECONSTRUCTION 2

Wright replaced the differential turntable by a large gear-wheel with 223 teeth. On top of this large gear-wheel he discovered an arrangement of two epicyclic wheels, the one directly above the other, but turning about separate axles on a stepped stud, coupled by a pin that projected from the face of the lower wheel into a radial slot in the upper one. See Figures 17 and 18. *Nota bene:* In Wright's model in Figures 17 and 18 there is a hypothetical extra wheel between E5 and K2; it has the same size as E5 and K2 and it is there merely in order to change the direction of the rotation. It would turn out to be superfluous. The stepped stud is fixed to the large gear-wheel. Let us consider E5 as the input. E5 engages K2. K2 engages K3 by means of the pin on K2 that slides in a slot in K3 and finally K3 engages E8. See Figure 13. All four wheels have fixed centres on the turntable E4.



**Fig. 15.** The pin and slot mechanism

This was a fascinating discovery. It is the earliest occurrence of a slider-crank mechanism in history that we know of. Let us look at what it does. The sine-rule applied to triangle ABC yields:

$$\frac{r}{\sin(\pi - \alpha)} = \frac{e}{\sin(\alpha - \beta)} \quad (3)$$

or

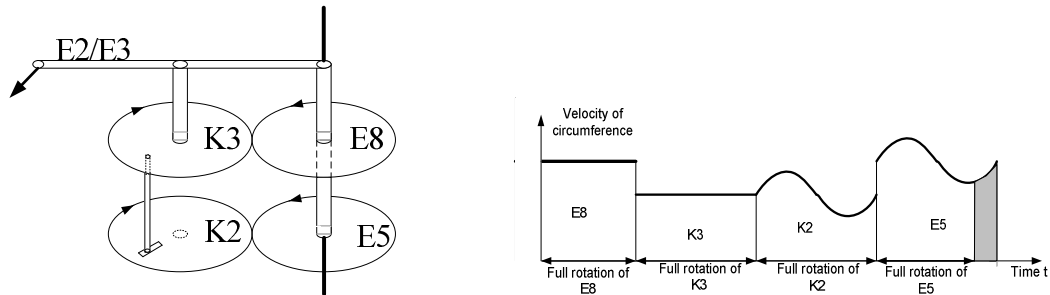
$$\sin(\alpha - \beta) = \frac{e}{r} \cdot \sin \alpha. \quad (4)$$

If  $\beta$  is the input angle and  $\alpha$  the output angle, then  $\theta = \alpha - \beta$  is the angle that is added to the input by the pin and slot mechanism. If  $e/r$  is small,  $\sin x$  is approximately equal to  $x$  and we can write

$$\theta = \frac{e}{r} \sin \alpha. \quad (5)$$

Indeed a roughly sinusoidal wave is introduced into the velocity ratio of the train, as Wright remarked (in [20] on p. 62).

Let us look at the whole mechanism. E8 engages K3. K3 engages K2 by means of the pin in the slot mechanism and finally K2 engages E5.

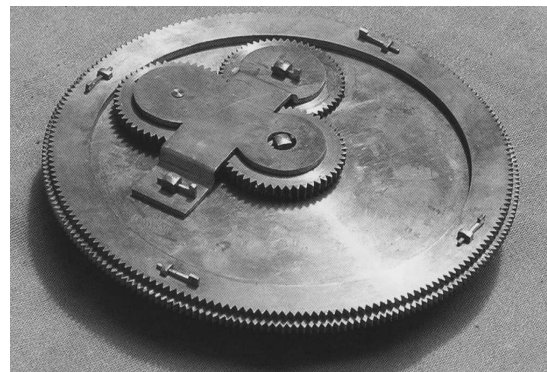


**Fig. 16.** The effect of the epicyclic pin-and-slot mechanism, on an input rotation of E8

We assume that the four wheels in the chain E8-K3-K2-E5 are of equal size. A uniform input velocity of E8 leads to a lower uniform velocity of K3 because the point where E8 and K3 touch shares the velocity of the epicyclic turntable. Nota bene: The rotations of K3 and K2 are considered with respect to the turntable and not with respect to the frame of the mechanism. In Figure 16 (right) the area E8 is equal to the area K3; the two areas measure the length of the circumference of the wheels E8 and K3. The pin-and-slot mechanism changes the uniform rotation of K3 into the wave of K2. Yet a full rotation of K2 takes as much time as a full rotation of K3. The area K2 measures the circumference of K2 and is equal to the area K3. At the point where K2 engages E5 the velocity that is transferred to E5 is increased by the velocity of the turntable. This means that a full rotation of E5 is completed before the period of the wave brought about by the pin and slot mechanism is completed.



**Fig. 17.** The epicyclic gearing showing the pin and slot coupling between the wheels on the K-axle [20]



**Fig. 18.** The epicyclic gear assembled [20]

Wright realized that such a mechanism could be used to model one of the anomalies figuring in astronomical theory, and as he wrote “the only possibility in this train, concerned with months, is lunar theory”. However, he added that the wave’s period was determined by the rate of rotation of the wheels relative to the epicyclic turntable and that neither period nor amplitude could be matched to the anomaly of Hipparchus’ lunar theory with the turntable going round at the rate he had conjectured. 19 revolutions of B1 corresponded to 254 revolutions of E6 and E8. How about the epicyclic turntable? Consider the chain E3-F1+F2-G2. In Wright’s reconstruction one rotation of the turntable corresponds to roughly 2 rotations ( $(190/54) \cdot (30/54)$  is approximately 2) of the main pointer on the lower back dial.

Wright could not make sense of the function of the gear train E5-K2+K3-E8. In his reconstruction of the gear trains Wright had got hold of all the pieces of the puzzle, but some of the pieces didn’t fall into place, they didn’t seem to make sense/ seemed to make no sense. For example, the large gear-wheel may be considered as composed of two concentric gear-wheels fixed together; one is slightly smaller than the other. The large one was unused in Wright’s reconstruction. The pin and slot mechanism did not seem to make sense either in the position it has. Unable to completely solve the puzzle Wright saw himself forced to suppose that the Antikythera mechanism had to a certain extent been constructed from reused parts derived from another, older mechanism.

### **THE RECONSTRUCTION BY FREETH *ET AL.***

Wright had the correct topography of the wheels and the correct understanding of most of the moving parts. He also had the correct layout of both back dials and the correct function of the main upper back dial. He had correctly identified the pin and slot mechanism. In addition, he had identified most of the details correctly, although some of them made no sense. In a sense he was close to the correct solution, but he was not quite there.

The clue to the final solution was in Athens in the National Archeological Museum. Wright had observed that some of the fractures were encrusted and/or eroded while others were bright and clean suggesting that they dated from after the salvage operation. Wright suspected that matching pieces that he had not seen might be present in the National Museum in Athens. He was right. Fragment F turned up in the Museum when the Antikythera Mechanism Research Project was started. Tony Freeth and others enlisted the help of Hewlett Packard (USA) and X-Tek Systems Ltd<sup>3</sup> (UK) and assembled a team of 17 individuals. The team published its results in November 2006 in *Nature* [5]. They confirmed the correctness of many of Wright’s results. However, there was more. The microfocus computed tomography (CT) by X-Tek Systems yielded a scan of Fragment F which showed some of the scale divisions on the lower back dial. Combining what they saw on Fragment F with the scale divisions visible on Fragments A and E, Freeth *et al.* estimated the number of scale divisions round the whole 4-turn spiral scale (observed by Wright) to be 223, exactly the number of months in a Saros cycle.<sup>4</sup>

---

<sup>3</sup> X-Tek Systems is now part of the Metris group.

<sup>4</sup> Freeth wrote to me that although Fragment F was the route by which the Antikythera Mechanism Research Group discovered that the lower back dial is a Saros dial all the evidence is already visible on Fragment A.

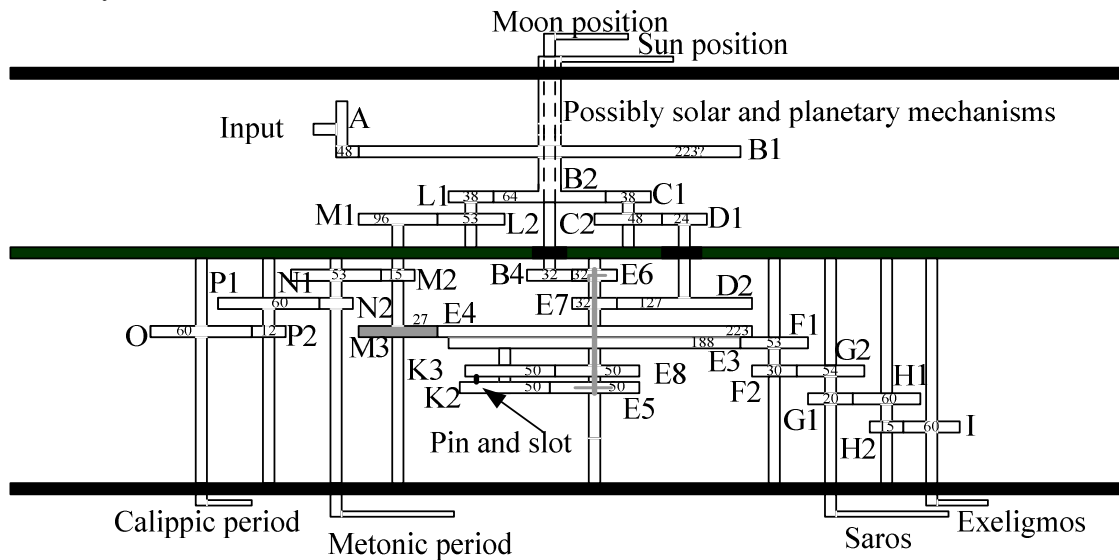
The assumption that the dial displayed a Saros cycle was reinforced by the discovery of characters on the dial separated by gaps of five or six months, precisely the gaps that separate eclipses.

Once it is known that the lower back dial shows where one is in a Saros cycle one can work back through the gear trains to see that an extra gear-wheel on the M axle can engage the unused gear-wheel in such a way that the Saros-cycle is generated at the right place.

Let us look at the details. The pointer of the Saros dial makes 4 rotations in 223 synodic months. In 19 years there are 235 synodic months. So when the wheel B1 corresponding to the position of the Sun makes 19 rotations, the axle G must make 4 times 235/223 rotations. What is needed is a gear train B2 to G2 that produces the right ratio using the wheels from the system of Figure 13. Wheel E4 is so far unused and it has 223 teeth. The train E4+E3-F1+F2-G2 is certainly the last part of the train we are looking for. The idea of introducing an extra wheel M3 on the M axle is now within reach, because there is no other simple way to get from B2 to E4.<sup>5</sup> On the basis of Wright's data it now follows that 19 rotations of B2 give

$$19 \times \frac{64}{38} \times \frac{53}{96} \times \frac{X}{223} \times \frac{\langle 188-192 \rangle}{\langle 53-55 \rangle} \times \frac{30}{\langle 54-55 \rangle} \quad (6)$$

rotations of the Saros pointer. Here X is the number of teeth of the new wheel M3 and <x-y> denotes an integer n in the interval x-y. This number must be equal to 4 times 235/223. It is easily verified that this implies that  $26 \leq X \leq 29$ . The precise values can be found by trial and error: M3 has 27 teeth, E3 has 188, F1 has 53 and G2 has 54 teeth.



<sup>5</sup> Wright informed me that the model of the mechanism that he built before the results of Freeth *et al.* became known had an empty square wheel-seat on axle M “ready to receive wheel M3”. He had observed it, seen the possibility that it suggested, and shelved it for later consideration.

**Fig. 19.** The reconstruction of the gear system by Freeth *et al.* The grey elements, wheel M3 and the inner E axle represent essential modifications of Wright's scheme.

As we have seen, Wright had been aware of the fact that the pin-and-slot mechanism could be used to generate an anomaly (a deviation from uniform motion in the orbit of a celestial body), but this made no sense to him at the time. However, as soon as the Saros cycle is supposed to be represented, the pin-and-slot mechanism and the large gear-wheel it is mounted on run roughly at the right speed for the anomaly of the Moon. With hindsight everything makes perfect sense. One of the two wheels E6 or E7 seemed superfluous. Not anymore. E7 rotates at the speed of the Mean Moon. So does E8 which is rigidly connected to it. The anomalous motion of the Moon is superimposed on this motion by the pin-and-slot mechanism. The result is the motion of E5 which is connected to E6 by means of an axle inside the axle of E7 and E8 (see Figure 19).

Although with hindsight things look easy it took Tony Freeth and Mike Edwards many months to draw the right conclusions about the function of the pin-and-slot mechanism. They published their findings in 2006 in *Nature*.

### **THE NEW METHODOLOGY AND ITS RESULTS**

The team that finally provided answers to the last remaining questions had seventeen members. In the team, led by Mike Edmunds (Cardiff University), two individuals from the National Archeological Museum of Athens catalogued and measured the fragments aided by an astronomer from Thessaloniki University. Six individuals from X-Tek Systems Ltd (Tring, Herts, U.K.) dealt with the building and operation of a Bladerunner CT machine that performed the 3-dimensional X-ray microfocus computed tomography (CT). They provided the CT reconstructions. Three individuals, two from Hewlett-Packard Inc. (California) and one from Foxhollow Technologies Inc. (California) built, operated and provided the software for the Polynomial Texture Mapping which was used to reveal surface details. Three Greek specialists read and translated the inscriptions. The first author, Tony Freeth (Cardiff University and Images First Ltd., London) took care of the analysis of the structure and its interpretation.

The contrast with Wright's approach could not be greater. Essentially Wright did everything alone. The approach of Freeth *et al.* was entirely different. Creating a group consisting of different specialists and engaging the most up-to-date technology available indeed represents a considerable methodological shift.

It was not clear in advance that this new approach would yield fruit. Jo Marchant reported in *Nature* that Freeth had said: "My main fear was that we'd throw all this technology at it and we wouldn't do more than dot the i's and cross the t's" ([8], p. 537). There was, indeed, a lot of technology. The team, for example, shipped an X-Tek machine of 12 tonnes to Athens in 2005. There is therefore a certain irony in the fact that the breakthrough in the interpretation of the gear trains and their interactions was largely the result of chance: the team had access to Fragment F.

In the mean time it has become clear that the new approach is yielding impressive results. In July 2008 Freeth *et al.* published a letter in *Nature* with the latest results concerning the two back dials. It turns out that the upper subsidiary dial is not the 76 year Calippic dial but follows the 4 year period of the Panhellenic games in Olympia, the predecessor of the Olympic games. A further discussion of these results falls beyond the scope of this

text. For more information on this text and the Antikythera Mechanism Research Project I refer the reader to the site <http://www.antikythera-mechanism.gr/>

## CONCLUSION

The first serious reconstruction of the gear system of the Antikythera mechanism was proposed by De Solla Price. It's most spectacular feature was a differential gear, which, however, proved to be a figment of the imagination. Yet, as Francis Bacon said, truth emerges more readily from error than from confusion, and Price's bold hypothesis gave a major stimulus to work on the mechanism. The next major step forward was Wright's reconstruction published in 2005. Wright had correctly identified most of the important details, but he was two essential steps away from the correct interpretation. Wright is convinced that if he had had access to 'Fragment F', he would have been able solve the riddle of the unused large gear-wheel and he would have understood the function of the mysterious pin and slot mechanism as well. His frustration that he didn't have access is understandable. The final solution was published in 2006 by Freeth and his team. It is not just the latest in a series of closer and closer approximations to the truth and more and more sophisticated interpretations of the Antikythera mechanism, but it is likely to be the last in the series, and final in the sense that it is basically correct.

## ACKNOWLEDGEMENTS

I am very grateful to Michael Wright and to Tony Freeth for reading an earlier version of this text and commenting on it. In fact they supplied me with so much information that I have undoubtedly failed to do justice to some of their remarks. I am also grateful to Tjeerd B. Jongeling for discussing several parts of the text with me which led to some important changes.

## REFERENCES

- [1] A.G. Bromley, Notes on the Antikythera Mechanism, *Centaurus* 29, 1986, pp. 5-27
- [2] A.G. Bromley, Observations on the Antikythera Mechanism, *Antiquarian Horology* 18, 1990, pp. 641-652
- [3] Mike Edmunds and Philip Morgan, The Antikythera Mechanism: still a mystery of Greek astronomy?, *Astronomy & Geophysics*, 41, 2000, pp. 6.10-6.17
- [4] Tony Freeth, The Antikythera Mechanism: I. Challenging The Classic Research, *Mediterranean Archaeology & Archaeometry* (MAA) Vol. 2, 2002, 21-35
- [5] Tony Freeth, The Antikythera Mechanism II: Is it Posidonius' Orrery?, *Mediterranean Archaeology & Archaeometry* (MAA) Vol. 2, 2002, pp. 45-58
- [6] Tony Freeth *et al.*, Decoding the ancient Greek astronomical calculator known as the Antikythera mechanism, *Nature* 444, 2006, pp. 587-591
- [7] Tony Freeth *et al.*, Calendars with Olympiad display and eclipse prediction on the Antikythera Mechanism, *Nature* 454, 2008, pp. 614-617
- [8] Alexander Jones, The development and transmission of 248-day schemes for lunar motion in ancient astronomy, *Archive for History of Exact Sciences* 29, 1983, 1-36
- [9] Jo Marchant, In search of lost time, News Feature in *Nature* 2006, pp. 534-538
- [10] Otto Neugebauer, *The Exact Sciences in Antiquity*, Dover Edition, 1969

- [11] Derek de Solla Price, Gears from the Greeks, The Antikythera Mechanism – a Calendar Computer from ca. 80 B.C., *Transactions of the American Philosophical Society*, New Series, Vol. 64, Part 7, 1974
- [12] G. J. Toomer, *Ptolemy's Almagest*, Duckworth, London, 1984
- [13] G. White, Antikythera Gearing – a different solution, *Horological Journal* 144, 2002, pp. 358-363
- [14] J. V. Field & M. T. Wright, Gears from the Byzantines: a portable sundial with calendrical gearing, *Annals of Science* 42, pp. 87-138. 1985 (reprinted in J. V. Field, D. R. Hill & M. T. Wright, *Byzantine and Arabic Mathematical Gearing*, London, Science Museum, 1985)
- [15] M. T. Wright, Rational and Irrational Reconstruction: the London Byzantine Sundial-Calendar and the Early History of Geared Mechanisms, *History of Technology*, 12, 1990, pp. 65-102
- [16] M. T. Wright, A Planetarium Display for the Antikythera Mechanism, *Horological Journal*, 144, 2002, pp. 169-173 and p. 193
- [17] M. T. Wright & A. G. Bromley, Towards a new reconstruction of the Antikythera mechanism, S. A. Paipetis (editor), *Extraordinary Machines and Structures in Antiquity*, Peri Technon, Patras, 2003, pp. 81-94.
- [18] M. T. Wright, Epicyclic gearing and the Antikythera mechanism, Part I, *Antiquarian horology* 27, 2003, pp. 270-279
- [19] M. T. Wright, The Scholar, the Mechanic and the Antikythera Mechanism, *Bulletin of the Scientific Instrument Society*, 80, 2004, pp. 4-11
- [20] M. T. Wright, Epicyclic gearing and the Antikythera mechanism, Part II, *Antiquarian horology* 29, 2005, pp. 51-63
- [21] M. T. Wright, The Antikythera Mechanism: a New Gearing Scheme, *Bulletin of the Scientific Instrument Society*, 85, 2005, 2-7
- [22] M. T. Wright, Counting Months and Years: the Upper Back Dial of the Antikythera mechanism, *Bulletin of the Scientific Instrument Society*, 87, 2005, pp. 8-13
- [23] E. C. Zeeman, The Antikythera Mechanisms, *Proceedings of the Royal Institution of Great Britain*, 58, 1986, pp. 137-156.