

A Multi-Agent System Architecture for Personal Support During Demanding Tasks

Tibor Bosse¹, Rob Duell², Mark Hoogendoorn¹, Michel Klein¹, Rianne van Lambalgen¹, Andy van der Mee², Rogier Oorburg², Alexei Sharpanskykh¹, Jan Treur¹, and Michael de Vos²

¹ Vrije Universiteit Amsterdam, Department of Artificial Intelligence
De Boelelaan 1081, 1081 HV Amsterdam, The Netherlands
{tbosse, mhoogen, mcaklein, rm.van.lambalgen, sharp, treur}@few.vu.nl

² Force Vision Lab, Barbara Strozziilaan 362a, 1083 HN Amsterdam, The Netherlands
{rob, andy, rogier, michael}@forcevision.nl

Abstract Task performance of humans that act under demanding circumstances may vary over time, depending on the characteristics of human, task and environment. To increase the effectiveness and efficiency of task performance, personalised assistance may be provided, in the form of automated personal assistant agents that constantly monitor the task execution and well-being of the human, and intervene when a problem is detected. This paper proposes a generic design for a multi-agent system architecture including such personal assistant agents, which can be deployed in a variety of domains.

1 Introduction

Systems supporting humans during execution of demanding tasks often need to fulfil two important requirements: 1) they need to be personalised to a specific human and his or her cognitive and task performance characteristics, and 2) they need to incorporate dynamical models for the analysis of the functioning of the human in a given task. For example, human task performance can degrade over time due to available resources being exceeded [6], which may lead to a reduction in attention and situation awareness [2, 3, 7]. By dynamical models involving the internal (exhaustion level, work pressure level) states of the human this can be predicted. As another example, it can be analysed whether the human remains healthy during the processes of task execution. Intelligent personal assistants proposed to support humans during the execution of tasks (see e.g. [4, 5]) depend on models that represent the state of the human and his or her tasks at particular time points, for example, a model addresses the cognitive load of the human (see e.g.

[8]). To provide more widely applicable assistance it is important to have a larger set of models from which an appropriate instance can be chosen depending on circumstances. This paper presents a generic design for a multi-agent system architecture including personal assistant agents. The personal assistant includes generic constructs that allow for self-configuration by loading domain-specific models and thus altering its own functionality. These domain-specific models also address the dynamics of states over time. A personal assistant agent can use these models to monitor and analyse the current state of the human and select the best intervention method (if needed) in the specific domain and task.

This paper is organised as follows. The multi-agent system architecture is described in Section 2. Model maintenance and state maintenance agents are discussed in Section 3. Further, the functions of the self-maintaining personal assistant agent are considered in Section 4. Finally, Section 5 concludes the paper.

2 The Agent-Based System Architecture

The developed conceptual component-based architecture comprises a number of essential components:

- *Process*: ensures request/provision of data from/to different components.
- *Reflection*: exercises control/monitoring over the functioning of the whole system. In particular, by performing meta-reasoning using human, task, system and environmental characteristics this component activates analysis methods.
- *Library of specifications* contains specifications of analysis methods, workflow, cognitive and dialogue models.
- *Storage of execution information* is used for storage and retrieval of information about the human, the world, the execution of workflows, dialogues and systems.

Given the essential components that have been identified above, the system has been modelled by a multi-agent system architecture consisting of the following types of agents:

- *Self-maintaining personal assistant agent* (SMPA) that supports a human operator during the execution of a task;
- *Model maintenance agent* (MMA) that contains a library of models used for the configuration of SMPA's.
- *State maintenance agent* (SMA) that maintains characteristics, states and histories of other agents, of the world and of the executions of tasks.
- *Mental operator agent* (MOA) that represents the mental part of the human operator.
- *Task execution support agent* (TESA) used by the human operator as an (active) tool during the execution of a task.

These agents are depicted graphically in Figure 1. The agents are represented as squares with small boxes on both sides (input and output). Another component of

the multi-agent system architecture is the physical world that comprises all material (or physical) objects including the body of the human operator. See the complete specification in [9] for more details. The personal assistants have two modes of functioning: (1) *the self-maintenance mode*, in which they are able to reason about the model specifications required to perform their tasks and to achieve their goals, to request these models and to load them (altering their functionality); (2) *the monitoring and guidance mode*, in which they perform monitoring and guidance of the human to whom they are related.

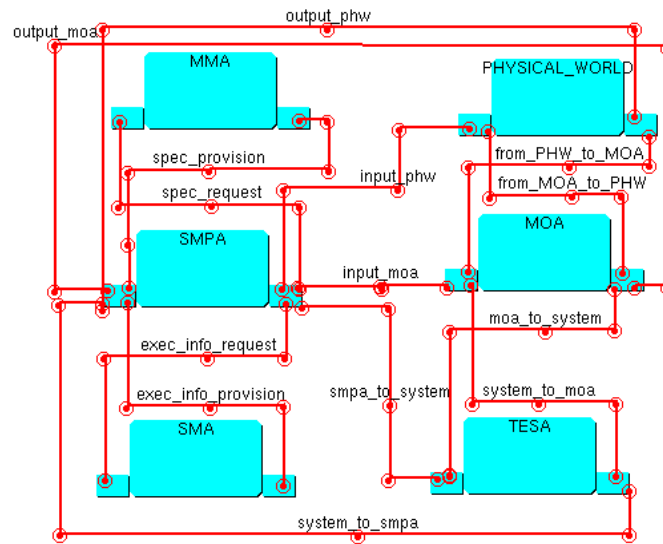

Fig. 1. Overview of the multi-agent system architecture.

In the self-maintenance mode communication takes place between personal assistant agents and model maintenance agents. In the monitoring and guidance mode personal assistant agents communicate with state maintenance agents, the mental operator agent, and task execution support agents. Furthermore, they interact with the physical world by performing observations (e.g., of the operator's state). The mental part of a human operator represented by a mental operator agent is connected to the operator's physical body, which can act in the physical world.

3 Maintenance Agents

Two types of maintenance agents are included in the multi-agent system architecture: model maintenance agents (MMA) and state maintenance agents (SMA).

The model maintenance agent contains a library of models that can be used by self-maintaining personal assistant agents to perform their tasks. Models of four types are maintained in the library: monitoring and guidance task models, cognitive models, workflow models, and dialogue models. Models are provided by the model maintenance agent to self-maintaining personal assistant agents upon request. To facilitate the model acquisition process, each maintained model is annotated by particular parameters. The ontology used for the annotation is assumed to be known to the agent-requester. In the general case, such an ontology may be also provided by the model maintenance agent to an self-maintaining personal assistant agent upon request. In Table 1 some of the parameters and their possible values used to annotate the different types of models are listed. The models maintained in model maintenance agents may be specified using different knowledge representation languages. However, it is important to ensure that a model provided to a self-maintaining personal assistant agent can also be interpreted by this agent. The state maintenance agent maintains information about the characteristics, states and histories of the agent types *mental operator agent* and *task execution support agent*, of the physical world, of the workflows and of dialogues related to them. Information about states and histories (i.e., sequences of states) is stored in a time-indexed format using the predicate $at(prop, time)$, where a state property is specified by the first argument and the time point at which this property holds is specified by the second argument.

Table 1. Cognitive and Workflow Model Parameters.

Parameter	Some possible values	Parameter	Some possible values
Cognitive models		Workflow models	
Name	string value	Name	string value
Cognitive processes	reasoning, consciousness, perception	Task type	string value
States	stress, motivation level, fatigue level	Task executor capabilities	excellent analytic skills, quick typing, domain-related knowledge
Agent type	robot, human, animal	Task executor traits	openness, extraversion, neuroticism
Related physical parts	frontal lobe, parietal lobe, temporal lobe	Minimum/maximum duration	integer value / integer value
Characteristics	qualitative/quantitative; stochastic; statistical	Consumable resources	building materials

Such information is gathered and provided to the state maintenance agent by self-maintaining personal assistant agents, which may also use this information in their analysis. Information for which a self-maintaining personal assistant agent has no immediate need after being stored in the state maintenance agent can be removed from the assistant agent's memory. When stored information is required

by a self-maintaining personal assistant agent, it can be requested from the state maintenance agent. An information request includes the identification of the element (i.e., mental operator agent, task execution support agent, physical world, a workflow, a dialogue), the aspect (i.e., characteristic, state, history) and the time interval for which information should be provided.

4 Self-Maintaining Personal Assistant Agent

For each human operator that needs to be supported during the task execution, a self-maintaining personal assistant agent is created. Initially, the personal assistant agent contains generic components only. The configuration of the personal assistant agent is performed based on an organisational role that needs to be supported by the agent, on the characteristics of a human operator who is assigned to this role, and on the goals defined for the personal assistant agent.

The human operator is assigned a role of being responsible for a package of tasks, which is provided to the personal assistant agent. For the whole task package, as well as for each task separately a set of goals and norms related to the execution of the task(s) may be defined. To determine the characteristics of the operator responsible for the execution of these tasks, the personal assistant agent sends a request to the state maintenance agent. If the operator is known to the state maintenance agent, his/her known professional, cognitive, psychological and physical characteristics are provided to the personal assistant agent. Otherwise, the state maintenance agent returns to the personal assistant agent the default profile (i.e., a standard set of characteristics).

For the personal assistant agent a set of prioritised general goals is defined, which it strives to achieve. Some of these goals are related to the quality of the task execution, others concern the operator's well-being. Based on information about the human operator and the assigned tasks, some of these goals may be refined and instantiated into more specific, operational goals. Next, the personal assistant agent will configure itself by identifying the suitable monitoring and guidance task model(s) that need(s) to be requested from the model maintenance agent. As soon as it possesses these models, it can perform monitoring and guidance of the human, according to four sub-processes: *monitoring* (i.e., determining which observation foci are needed), *analysis* (detecting potential problems and their causes), *plan determination* (determining plans to remedy these problems), and *plan execution preparation* (refining these plans by relating them to specific actions to execute).

More details about the functioning of the self-maintaining personal assistant agent, as well as a prototype implementation (and an example simulation trace) can be found in [1].

5 Conclusion

In this paper, a multi-agent system architecture for personal support during task execution has been proposed. This architecture includes self-maintaining personal assistant agents with a generic design. Such agents possess self-configuration abilities, which enable them to dynamically load domain-specific models, thereby specialising these agents for the execution of particular tasks in particular domains. Using these models and information about the assigned goals and tasks, the personal assistant agent performs monitoring and analysis of the behaviour of the supported human in his/her environment. In case a known problem is detected, the agent tries to identify and execute an appropriate intervention action. The fact that the architecture is generic differentiates the approach from other personal assistants such as presented in [4, 5]. The proposed self-maintaining personal assistant agent has an advantage of being relatively lightweight, as it only maintains and processes those models that are actually needed for the performance of the tasks. It can therefore run upon for instance a PDA or cell phone. To provide the required functionality for personal assistant agents, the proposed architecture includes model maintenance and state maintenance agents.

References

1. Bosse, T., Duell, R., Hoogendoorn, M., Klein, M.C.A., Lambalgen, R. van, Mee, A. van der, Oorburg, R., Sharpanskykh, A., Treur, J., and Vos, M. de (2009). *A Generic Personal Assistant Agent for Support in Demanding Tasks*. In: Proc. of the Fourth International Conference on Augmented Cognition and 13th Int. Conference on Human-Computer Interaction, HCI'09. Lecture Notes in Computer Science, Springer Verlag, 2009, to appear.
2. Endsley, M.R. (1997). The role of situation awareness in naturalistic decision making. In C. Zsombok G. Klein (Eds.), *Naturalistic decision making*: 269- 284. Mahwah, NJ: Erlbaum.
3. Endsley, M.R. (2000). Theoretical underpinnings of situation awareness. In M.R. Endsley & D.J. Garland (Eds.) *Situation awareness analysis and measurement* (pp. 1-21). Mahwah, NJ: Erlbaum.
4. Modi, P.J., Veloso, M., Smith S.F., and Oh, J., CM Radar: A Personal Assistant Agent for Calendar Management. In: Bresciani, P. et al. (eds.), AOIS II, LNCS 3508, Springer, 2005, pp. 169-181.
5. Myers, K., Berry, P., Blythe, J., Conley, K., Gervasio, M., McGuinness, D.L., Morley, D., Pfeffer, A., Pollack, M., and Tambe, M., An Intelligent Personal Assistant for Task and Time Management. AI Magazine Summer 2007, pp. 47-61.
6. Posner, M. I., and Boies, S. J. 1971. Components of attention. *Psychological Bulletin* 78:391-408.
7. Wickens, C.D. (2002). Situation awareness and workload in aviation. *Current Directions in Psych. Science*, 11, 128-133.
8. Wilson, G.F., & Russell, C.A. (2007). Performance enhancement in an uninhabited air vehicle task using psychophysiological determined adaptive aiding. *Human Factors*, 49(6), 1005-1018.
9. <http://www.cs.vu.nl/~wai/PersonalAssistant/>